

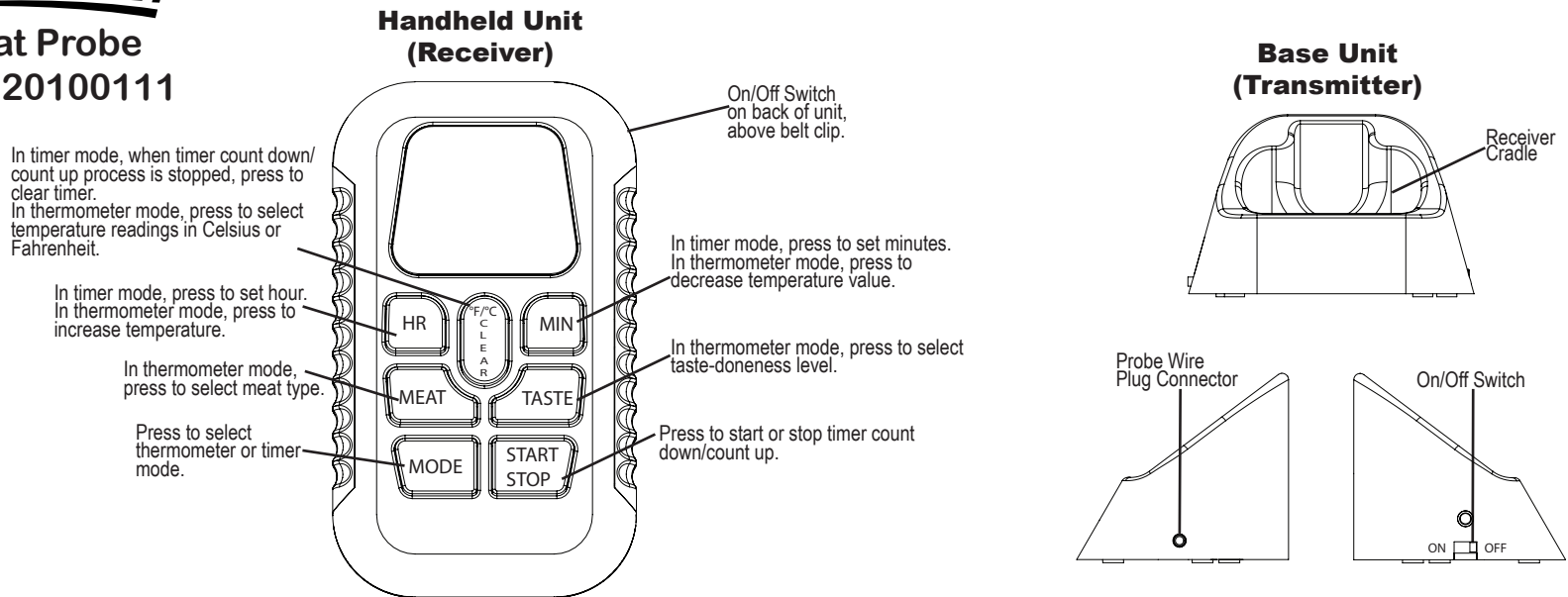

MASTERBUILT

Digital Meat Probe

Model No. 20100111



GENERAL USE INSTRUCTIONS

1. Locate the battery compartments and load 2AAA batteries (not included) into both Handheld Unit (Receiver) and Base Unit (Transmitter).
2. Place Handheld unit in Base Unit cradle (units should be in close proximity for establishing data link).
3. Place meat on grill or in oven.
4. Insert stainless-steel meat probe into thickest part of the meat.
5. Carefully, replace/close grill lid or oven door on heat-resistant braided steel wire.
6. Plug probe wire into Base unit.
7. Turn ON the Handheld Unit and Base Unit by locating both small "ON/OFF" switches.
8. Handheld Unit and Base Unit will establish data link automatically. Registration is complete when the Handheld Unit beeps and the probe temperature appears where the "—" was flashing.
9. Once link is established, enter type of meat (Beef, Veal, Lamb, Pork, Chicken, Turkey) by pressing meat button on Handheld Unit until desired meat is selected.
10. Once meat type is selected, set desired taste level (Rare, Medium-Rare, Medium, Well-Done) by pressing taste button on Handheld Unit until desired taste/doneness level is selected.
11. To set the desired internal meat temperature manually. Press HR or MIN button to raise or lower the temperature value after meat selection is made.
12. Grill or Cook until alarm sounds indicating that the desired taste/doneness level is reached. For the best results set count down/count up timer and check meat periodically (see timer instructions).
13. Remove meat from grill or oven and allow to cool and serve.

FOR BEST RESULTS

1. Make sure probe tip is inserted into the meat at least 1 inch.
2. Do not allow the probe or probe wire to come in direct contact with flames. If cooking with grill cover closed, only use medium and low heat.
3. Make sure that probe tip is inserted into the center of meat (not poking through meat).

TIMER INSTRUCTIONS

Count Down Timer:

1. Press MODE to select timer mode. The upper display will show a small TIMER and 0:00.
2. Press HR and MIN button to set the timer. Press START/STOP button to start count down timer. "▼" will blink for every second.
3. To stop countdown timer, press START/STOP button again. The "▼" becomes solid.
4. Press CLEAR button to clear the setting back to 0:00.

Count Up Timer:

1. Press MODE to select timer mode. The upper display will show a small TIMER and 0:00.
2. Press START/STOP button to start count up. The "▲" will blink for every second.
3. To stop count timer, press START/STOP button again. The "▲" becomes solid.
4. Press CLEAR button to clear the setting back to 0:00.

HANDHELD UNIT BATTERY REPLACEMENT

1. Locate the battery compartment under belt clip on the backside of the unit.
2. Slide belt clip off to access battery compartment.
3. Carefully, remove battery cover.
4. Load 2AAA batteries (not included).
5. Replace battery cover and belt clip.

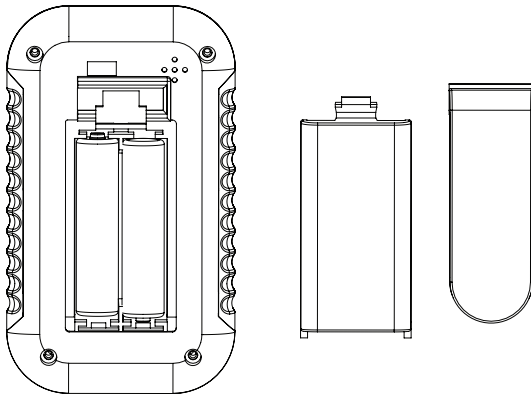

BASE UNIT BATTERY REPLACEMENT

1. Locate the battery compartment on bottom of unit.
2. Carefully, remove battery cover.
3. Load 2AAA batteries (not included).
5. Replace battery cover.

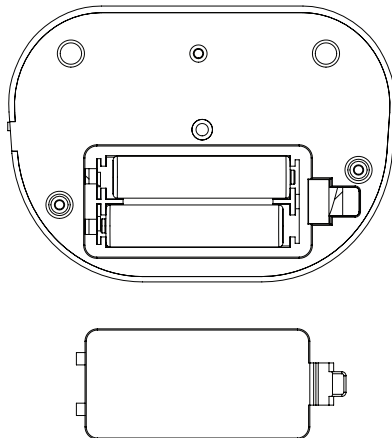

TROUBLE SHOOTING

Problem: Cannot make meat selection.

Solution: May be in timer mode. Check to make sure that the Handheld Unit (Receiver) is in the thermometer mode by pressing MODE button.

Problem: No data link between Handheld Unit (Receiver) and Base Unit (Transmitter).

Solutions: Check to make sure that both units are turned ON while in close proximity to one another.
Check batteries for replacement.

CLEANING INSTRUCTIONS

1. Hand wash probe with soap and water.
2. Do not immerse probe in water while cleaning.
3. Dry immediately.
4. Do not wash Handheld Unit (Receiver) or Base Unit (Transmitter).
5. Unit is not Dishwasher Safe.

CAUTION!

1. Meat probe and wire are very hot while in use.
2. Always use a heat-resistant glove when handling meat probe or probe wire while in use. Do not touch with bare hands.
3. Do not expose Handheld Unit (Receiver) or Base Unit (Transmitter) to direct heat or hot surfaces.
4. Not for use in microwave ovens.
5. Do not expose Base Unit (Transmitter) or meat probe plug connector to water.
6. Do not use Handheld Unit (Receiver) or Base Unit (Transmitter) in the rain.
7. Base Unit (Transmitter) registers temperatures as low as 14

FCC NOTE:

THE MANUFACTURER IS NOT RESPONSIBLE FOR ANY RADIO OR TV INTERFERENCE CAUSED BY UNAUTHORIZED MODIFICATIONS TO THIS EQUIPMENT. SUCH MODIFICATIONS COULD VOID THE USER'S AUTHORITY TO OPERATE THE EQUIPMENT.

This device complies with Part 15 of the FCC Rules. Operation is subject to the following two conditions:

1. This device may not cause harmful interference, and
2. This device must accept any interference received, including interference that may cause undesired operation. Note: This equipment has been tested and found to comply with the limits for a Class B digital device, pursuant to part 15 of the FCC Rules.