

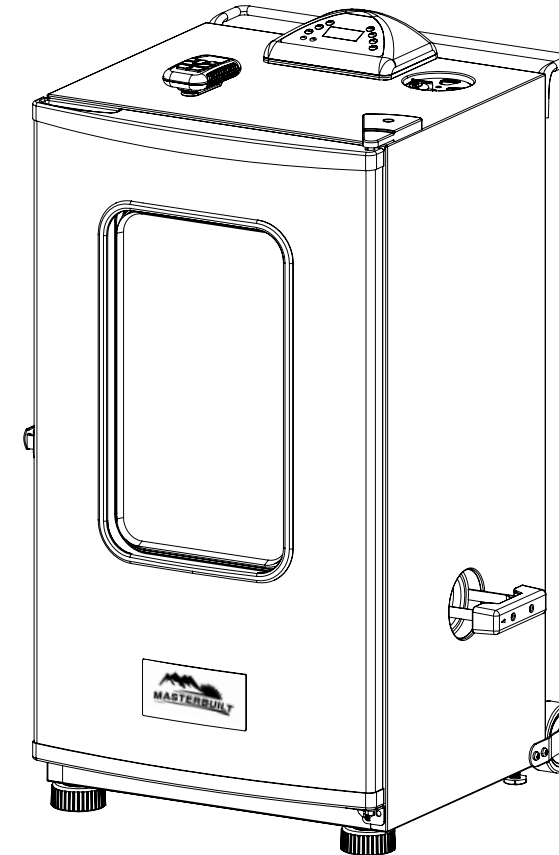

Masterbuilt Manufacturing, Inc.  
 1 Masterbuilt Ct.  
 Columbus, GA 31907  
 Customer Service 1-800-489-1581  
 www.masterbuilt.com







**ASSEMBLY, CARE & USE MANUAL  
 WARNING & SAFETY INFORMATION  
 ELECTRIC SMOKER MODEL 20071111  
 THIS PRODUCT IS FOR OUTDOOR USE ONLY**



Manual Code: 9807110007 061311 -04JH

Approximate assembly time : 15 minutes

Tool needed for assembly: Phillips Head Screwdriver

 <b>CARBON MONOXIDE HAZARD</b> 	 <b>WARNING</b> 
<p>Burning wood chips gives off carbon monoxide, which has no odor and can cause death.</p> <p><b>DO NOT</b> burn wood chips inside homes, vehicles, tents, garages or any enclosed areas.</p> <p>Use only outdoors where it is well ventilated.</p>	<p>This manual contains important information necessary for the proper and safe use of this unit.</p> <p>Read and follow all warnings and instructions before using smoker and during use.</p> <p>Keep this manual for future reference.</p> <p>Some parts may have sharp edges handle with care.</p>
<p><b>Failure to follow these warnings and instructions properly could result in personal injury or death.</b></p>	



## GENERAL WARNINGS AND SAFETY INFORMATION



### READ ALL INSTRUCTIONS

When using electrical appliances, basic safety precautions should always be followed including the following:

- For outdoor use only. Do not operate in an enclosed area.
- Unit **MUST** be on the ground. Do not place unit on tables or counters. Do **NOT** move unit across uneven surfaces.
- Do not lift unit by rear handle.
- Do not plug in electric smoker until fully assembled and ready for use.
- Use only approved grounded electrical outlet.
- Do not use during an electrical storm.
- Do not expose electric smoker to rain or water at anytime.
- To protect against electrical shock do not immerse cord, plug, or control panel in water or other liquid.
- Do not operate any appliance with a damaged cord or plug, or after appliance malfunctions or has been damaged in any manner. Contact Masterbuilt Customer Service for assistance at 1-800-489-1581.
- Keep a fire extinguisher accessible at all times while operating electric smoker.
- Do not let cord hang touch hot surfaces.
- Do not place on or near a hot gas or electric burner, or in a heated oven.
- Keep children and pets away from electric smoker at all times. Do not allow children to use electric smoker. Close supervision is necessary should children or pets be in area where electric smoker is being used.
- Fuel, such as charcoal briquettes or heat pellets, are not to be used in electric smoker.
- Never use electric smoker as a heater (READ CARBON MONOXIDE HAZARD).
- Use electric smoker only on a level, stable surface to prevent tipping.
- Electric smoker is **HOT** while in use and will remain **HOT** for a period of time afterwards. Use caution.
- Do not touch **HOT** surfaces.
- Do not allow anyone to conduct activities around electric smoker during or following its use until the unit has cooled. Electric smoker is **HOT** during operation and remains **HOT** for a period of time following use.
- The use of alcohol, prescription or non-prescription drugs may impair the user's ability to properly assemble or safely operate electric smoker.

WARNINGS & IMPORTANT SAFEGUARDS CONTINUED ON PAGE 2

## LIMITED WARRANTY

Masterbuilt warrants its products to be free from defects in material and workmanship under proper assembly, normal use and recommended care for 90 days from the date of original retail purchase. Masterbuilt warranty does not cover paint finish as it may burn off during normal use. Masterbuilt warranty does not cover rust of the unit.

Masterbuilt requires reasonable proof of purchase for warranty claims and suggests that you keep your receipt. Upon the expiration of such warranty, all such liability shall terminate.

Within the stated warranty period, Masterbuilt, at its discretion, shall repair or replace defective components free of charge with owner being responsible for shipping. Should Masterbuilt require return of component(s) in question for inspection Masterbuilt will be responsible for shipping charges to return requested item. This warranty excludes property damage sustained due to misuse, abuse, accident, damage arising out of transportation, or damage incurred by commercial use of this product.

This expressed warranty is the sole warranty given by Masterbuilt and is in lieu of all other warranties, expressed or implied including implied warranty, merchantability, or fitness for a particular purpose. Neither Masterbuilt nor the retail establishment selling this product, has authority to make any warranties or to promise remedies in addition to or inconsistent with those stated above.

Masterbuilt's maximum liability, in any event, shall not exceed the purchase price of the product paid by the original consumer/ purchaser. Some states do not allow the exclusion or limitation of incidental or consequential damages. In such a case, the above limitations or exclusions may not be applicable.

**California residents only:** Notwithstanding this limitation of warranty, the following specific restrictions apply; if service, repair, or replacement of the product is not commercially practical, the retailer selling the product or Masterbuilt will refund the purchase price paid for the product, less the amount directly attributable to use by the original buyer prior to the discovery of the nonconformity. Owner may take the product to the retail establishment selling this product in order to obtain performance under warranty. This expressed warranty gives you specific legal rights, and you may also have other rights which vary from state to state.



Go Online [www.masterbuilt.com](http://www.masterbuilt.com)  
or complete and return to  
Attn: Warranty Registration  
Masterbuilt Mfg. Inc.  
1 Masterbuilt Court - Columbus, GA 31907

Name: \_\_\_\_\_ Address: \_\_\_\_\_ City: \_\_\_\_\_

State/Province: \_\_\_\_\_ Postal Code: \_\_\_\_\_ Phone Number: (\_\_\_\_) - \_\_\_\_\_

E-mail Address: \_\_\_\_\_

\*Model Number: \_\_\_\_\_ \*Serial Number: \_\_\_\_\_

Purchase Date: \_\_\_\_ - \_\_\_\_ - \_\_\_\_ Place of Purchase: \_\_\_\_\_

\*Model Number and Serial Number are located on silver label on back of unit.

This device complies with Part 15 of the FCC Rules. Operation is subject to the following two conditions :

- (1) this device may not cause harmful interference, and
- (2) this device must accept any interference received, including interference that may cause undesired operation.

#### **FCC Warning**

Warning: Changes or modifications to this unit not expressly approved by the party responsible for compliance could void the user's authority to operate the equipment.

#### **FCC Statement**

NOTE: This equipment has been tested and found to comply with the limits for a Class B digital device, pursuant to Part 15 of the FCC Rules. These limits are designed to provide reasonable protection against harmful interference in a residential installation. This equipment generates uses and can radiate radio frequency energy and, if not installed and used in accordance with the instructions, may cause harmful interference to radio communications.

However, there is no guarantee that interference will not occur in a particular installation. If this equipment does cause harmful interference to radio or television reception, which can be determined by turning the equipment off and on, the user is encouraged to try to correct the interference by one or more of the following measures:

1. Reorient or relocate the receiving antenna.
2. Increase the separation between the equipment and receiver.
3. Connect the equipment into an outlet on a circuit different from that to which the receiver is connected.
4. Consult the dealer or an experienced radio/TV technician for help.



## **GENERAL WARNINGS AND SAFETY INFORMATION**



- **Avoid bumping or impacting electric smoker.**
- **Never move electric smoker when in use. Allow electric smoker to cool completely before moving or storing.**
- **Be careful when removing food from electric smoker. All surfaces are HOT and may cause burns. Use protective gloves or long, sturdy cooking tools.**
- **Do not cover cooking racks with metal foil. This will trap heat and cause severe damage to electric smoker.**
- **Drip tray is only for the bottom of electric smoker. Do not put drip tray on cooking racks this may damage electric smoker.**
- **Wood tray is HOT when electric smoker is in use. Use caution when adding wood.**
- **To disconnect, turn control panel "OFF", then remove plug from outlet.**
- **Unplug from outlet when not in use and before cleaning. Allow unit to cool completely before adding/removing grates, tray or water bowl.**
- **Dispose of cold ashes by placing them in aluminum foil, soaking with water and discarding in a non-combustible container.**
- **Do not store electric smoker with HOT ashes inside unit. Store only when all surfaces are cold.**
- **Accessory attachments not supplied by Masterbuilt Manufacturing, Inc. are not recommended and may cause injury.**
- **The use of accessory attachments not recommended by the appliance manufacturer may cause injuries.**
- **Never use electric smoker for anything other than its intended purpose. This unit is not for commercial use.**
- **Always use electric smoker in accordance with all applicable local, state and federal fire codes.**
- **Longer extension cords are available and may be used if care is exercised in their use.**
- **If a longer extension cord is used the marked rating should be at least as great as the electrical rating of the appliance.**
- **The extension cord must be a grounding -type 3-wire cord.**
- **Outdoor extension cords must be used with outdoor use products and are marked with suffix "W" and with the statement "Suitable for Use with Outdoor Appliances.**
- **CAUTION - To reduce the risk of electric shock, keep extension cord connection dry and off the ground.**
- **Extreme caution must be used when moving an appliance containing hot liquids.**
- **Do not clean this product with a water spray or the like.**

**SAVE THESE INSTRUCTIONS**

## LET'S GET STARTED!

- This is a slow smoker...allow sufficient time for cooking. Smoker is for OUTDOOR USE ONLY.
- "Preseason" smoker prior to first use. See page 11.
- Pre-heat smoker for 30 to 45 minutes at max temperature before loading food.
- DO NOT cover racks with aluminum foil as this will not allow heat to circulate properly.
- Do not overload smoker with food. Extra large amounts of food may trap heat, extend cooking time and cause uneven cooking. Leave space between food on racks and smoker sides to ensure proper heat circulation. If utilizing cooking pans, place pans on center of rack to ensure even cooking. Please see manual for more detail.
- Close air damper on top of unit to retain moisture and heat. If cooking foods such as fish or jerky, open air damper to release moisture.
- Temperature reading on control panel will fluctuate + or - 10 to 15 degrees as smoker cycles on and off.
- Store smoker in a dry area after use.
- Extreme cold temperatures may extend cooking times.
- CLEAN AFTER EVERY USE. This will extend the life of your smoker and prevent mold and mildew.

ENJOY!



### WARNING



COMBUSTION BY-PRODUCT PRODUCED WHEN USING THIS PRODUCT CONTAINS CHEMICALS KNOWN TO THE STATE OF CALIFORNIA TO CAUSE BIRTH DEFECTS, OTHER REPRODUCTIVE HARM, OR CANCER.

THE MATERIALS USED IN THIS PRODUCT MAY CONTAIN LEAD A CHEMICAL KNOWN TO THE STATE OF CALIFORNIA TO CAUSE BIRTH DEFECTS AND OTHER REPRODUCTIVE HARM.

## RECIPES

### SMOKED TUNA

- 4 Tuna Steaks (1" thick)
- 1 1/8 cup Sugar
- 3/8 cup Salt
- 1 tsp Pepper
- 1/4 tsp Garlic (granulated)
- 1/4 tsp Prague Powder #1
- 1 cup Honey
- 1 gal Water

*Suggested wood chips for smoking:*

Hickory or Apple Chips

Mix above ingredients until dissolved in water. Place in pre-heated smoker at 140 degrees and cook for about 7 hours using water mixture in water pan.

### SMOKED PORK BUTT

- 7 lbs Fresh pork butt
- 1/2 tsp Salt
- 1/4 cup Brown Sugar
- 2 tbsp Chili Powder

*Suggested wood chips for smoking:*

Apple Chips

Mix ingredients and rub onto pork butt. Cook pork butt for 5 hours in 225 degree pre-heated smoker using apple wood chips during the first 3 hours. After 5 hours remove butt and wrap in heavy foil. Cook for an additional 1 to 1 1/2 hours. Internal temperature should be 160 degrees. Serve.

For more tantalizing recipes and cooking tips visit us online at [www.masterbuilt.com](http://www.masterbuilt.com)

## WOOD SMOKING GUIDE FOR MEATS

WOOD FLAVOR	POULTRY	FISH	HAM	BEEF	PORK	LAMB
<b>Hickory</b> Pungent, smoky, bacon-like flavor	✓	✓	✓	✓	✓	
<b>Mesquite</b> Sweet and delicate flavor	✓			✓		✓
<b>Alder</b> Delicate, wood smoke flavor	✓	✓			✓	
<b>Pecan</b> Bold and hearty flavor	✓	✓			✓	
<b>Maple</b> Sweet, subtle flavor	✓				✓	
<b>Apple</b> Sweet, delicate flavor	✓	✓			✓	
<b>Cherry</b> Sweet, delicate flavor	✓				✓	

## IMPORTANT FACTS ABOUT USING SMOKER

- Maximum temperature setting is 275°F (135°C).
- Do NOT move unit across uneven surfaces.
- Rear handle is NOT for lifting.
- Wood chip loader and wood chip holder MUST be in place when using smoker. This minimizes the chance of wood flare ups.
- Wood chips must be used in order to produce smoke and create the smoke flavor. See “Wood Smoking Guide for Meats” section in this manual.
- Check grease tray on back of unit often during cooking. Empty grease tray before it gets full. Grease tray may need to be emptied periodically during cooking.
- Do not open smoker unless necessary. Opening smoker door causes heat to escape and may cause wood to flare up. Closing the door will re-stabilize the temperature and stop flare up.
- Do not leave old wood ashes in the wood tray. Once ashes are cold empty tray. Tray should be cleaned out prior to and after each use to prevent ash buildup.
- Glass in door is tempered and will not break under normal operation.
- This is a smoker. There will be a lot of smoke produced when using wood chips. Smoke will escape through seams and turn the inside of smoker black. This is normal. To minimize smoke loss around door, door latch can be adjusted to further tighten door seal against body.

- To adjust door latch, loosen hex nut on door latch. Turn hook clockwise to tighten as shown. Secure hex nut firmly against door latch.
- Opening smoker door during cooking process may extend cooking time due to heat loss.
- When outside temperature is cooler than 65°F (18°C) and/or altitude is above 3,500 feet (1067m), additional cooking time may be required. To insure that meat is completely cooked use a meat thermometer to test internal temperature.

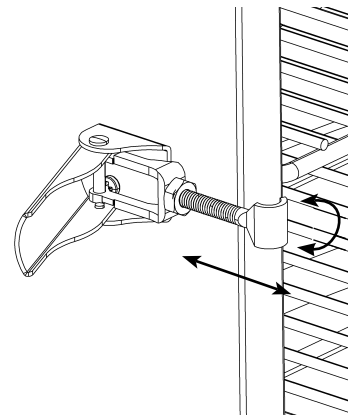

## HOW TO CLEAN SMOKER

For cooking racks, water bowl and drip tray, use a mild dish detergent. Rinse and dry thoroughly.

For wood chip holder and wood chip loader, clean frequently to remove ash build up, residue and dust.

For the interior, glass in door, light cover, meat probe, and exterior of smoker simply wipe down with a damp cloth. Do not use a cleaning agent. Make sure to dry thoroughly.

Door seal and inside seam that seal attaches to MUST be cleaned after each use to keep seal in proper working condition.

**ALWAYS MAKE SURE UNIT IS UNPLUGGED AND COOL TO THE TOUCH BEFORE CLEANING AND STORING.**



## DO NOT RETURN TO RETAILER

For Assembly Assistance, Missing or Damaged Parts  
Call: MASTERBUILT Customer Service at 1-800-489-1581.

## PARTS LIST

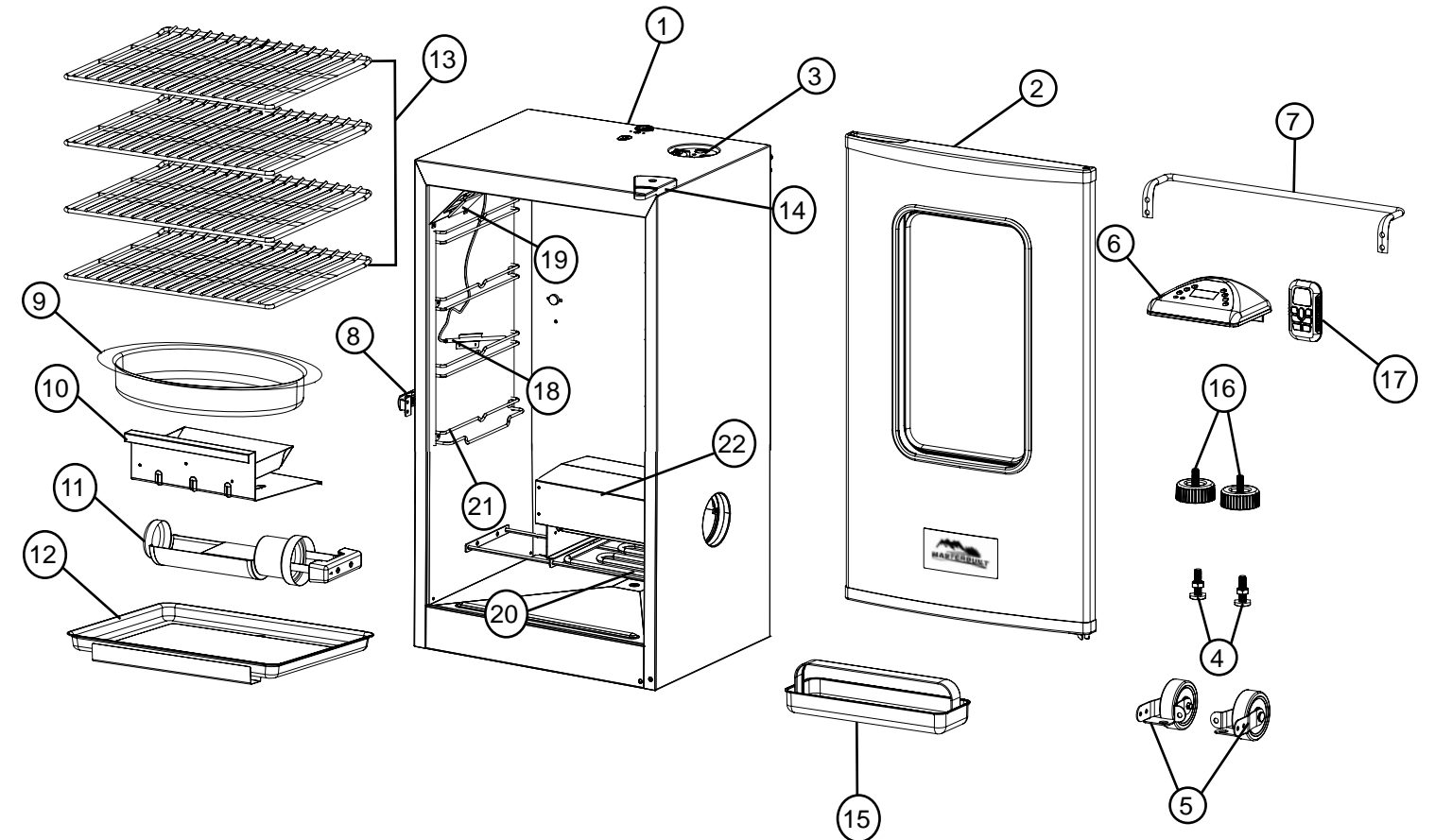

PART NO	QUANTITY	DESCRIPTION	PART NO	QUANTITY	DESCRIPTION
1	1	Smoker Body	12	1	Drip Pan
2	1	Smoker Door	13	4	Smoking Rack
3	1	Air Damper	14	1	Door Hinge
4	2	Adjustable Screw Leg	15	1	Grease Tray
5	2	Wheels	16	2	Leg Boot
6	1	Digital Control	17	1	Wireless Remote Control
7	1	Rear Handle	18	1	Meat Probe
8	1	Door Latch	19	1	Light Bulb Cover
9	1	Water Bowl	20	1	Element
10	1	Wood Chip Tray	21	2	Cooking Grate Support Rack
11	1	Wood Chip Loader	22	1	Wood Chip Lid

## HARDWARE LIST

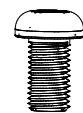

(A)  
M5\*14  
Phillips Screw  
Qty: 12

## PARTS LIST

PART NO	REPLACEMENT PART	ITEM NO
1	Body Kit	9907100002
2	Door with Window	9907090028
3	Air Damper Kit	990060221
4	Adjustable Screw Leg	910050006
5	Wheel Kit	9907100004
6	Digital Control Kit	9907100001
7	Rear Handle Kit	9907100015
8	Door Latch Kit	990070018
9	Water Bowl	910050030
10	Wood Chip Tray	9007100018
11	Wood Chip Loader	9007090093
12	Drip Pan	910070028
13	Smoking Rack	910050029
14	Door Hinge Kit	9907090041
15	Grease Tray	910060047
16	Leg Boot	910050009
17	Wireless Remote Control	9007100008
18	Meat Probe	9007080006
19	Light Bulb Cover Kit	9907090035
20	Element Kit	9907090033
21	Cooking Grate Support Rack Kit	990050049
22	Wood Chip Lid Kit	9907100013
	Element Support Rack Kit	990070020
	Grease Tray Bracket Kit	9900500024
	Hardware Kit - Body	9907100006
	Hardware Kit - Control Panel	998050010
	Instruction Manual	9807110007

**DO NOT RETURN TO RETAILER** For Assembly Assistance, Missing or Damaged Parts  
Call: MASTERBUILT Customer Service at 1-800-489-1581.  
Please have Model Number and Serial Number available when calling.  
These numbers are located on silver label on back of unit.



## TROUBLESHOOTING GUIDE

SYMPTOM	CAUSE	POSSIBLE SOLUTION
Power light wont come	Not plugged into wall	Check wall connection
	House fuse tripped	Make sure other appliances are not operating on the same electrical circuit. Check household fuses.
	Wire connector on controller not properly connected to smoker	See Step 2 on Page 5
	Controller malfunctioning	Contact Masterbuilt at 1.800.489.1581
Unit takes excessive amount of time to heat up (longer than 60-70 min)	Unit plugged into an extension cord	Set unit so an extension cord does not have to be used
	Door not closed properly	Close door and fasten latch securely
	Controller malfunctioning	Contact Masterbuilt at 1.800.489.1581
There is a gap between the door and the smoker when in use and door latch has no more adjustment	Door alignment	Contact Masterbuilt at 1.800.489.1581
	Damaged door seal	
Grease is leaking out of smoker through door and legs	Drip pan not in place	Reposition so hole lines up with drain hole in bottom of unit
	Excess grease or oil build-up in unit	Clean unit
	Drain tube in back of unit is not draining	Check drain tube positioning at back of unit
No smoke	No wood chips	Add wood chips (See Page 11)
Temperature rapidly decreased, or shut down after few hours of use	Faulty control unit	Contact Masterbuilt at 1.800.489.1581
Controller displaying error message	Controller malfunctioning	Contact Masterbuilt at 1.800.489.1581
Power light is on, unit isn't heating	Controller/unit malfunctioning	Contact Masterbuilt at 1.800.489.1581
Controller does not adjust heat	Controller/unit malfunctioning	Contact Masterbuilt at 1.800.489.1581
Interior light does not come on	Bulb burned out	Replace bulb with 15W-25W bulb made for ovens
	Switch is in off position	Turn switch on
Meat probe temperature does not show on display	Probe malfunctioning	Contact Masterbuilt at 1.800.489.1581
Remote will not control smoker	Batteries are weak or installed wrong	Refer to page 13 instructions
	Remote is not linked properly to controller	Contact Masterbuilt at 1.800.489.1581
	Remote malfunctioning	

## HOW TO USE CONTROL PANEL & REMOTE CONTROL

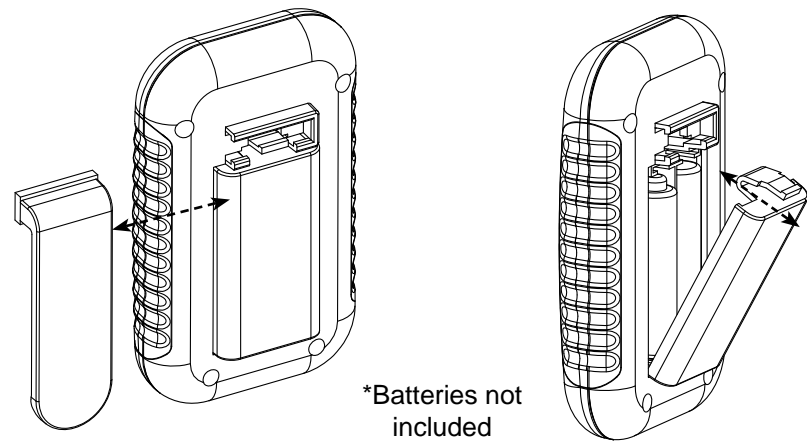

\*Batteries not included

### To replace batteries:

- Slide belt clip to the left to remove.
- Press tab down on battery cover and pull out.
- Install 2 “AAA” Alkaline batteries. Check positive (+) and negative (-) symbols, on the case and battery, to insure proper installation.
- Replace the battery cover.
- Remove batteries before storing remote control.

### To test frequency range:

- Turn unit on.
- Use remote to turn light on and off as you move away from unit.
- Remote control is out of frequency range when light will no longer turn on and off.

### IMPORTANT

- Do not leave remote control exposed to sunlight for prolonged periods of time.
- Remote control has frequency range of up to 100ft (30m).
- Test frequency range before and during use.

### TROUBLESHOOTING

If the remote is not working properly or not interfacing correctly with the controller, it may be due to weak batteries, batteries being incorrectly installed or the remote is not correctly linked to controller.

### Possible solutions

- Replace batteries and install according to image in battery housing
- Link remote and controller by:
  - a. Turn Controller & Remote “ON”,
  - b. Press and HOLD “SET TEMP” on controller for 3 seconds.
  - c. On the Remote press “MEAT PROBE”, “LIGHT”, “MEATPROBE”, “LIGHT” (*all buttons must be pressed within 5 seconds of each other*) A short beep will occur after each button press.



- Keep batteries away from small children. If battery is swallowed consult a physician immediately.
- Be sure to insert batteries correctly. Improper installation may result in leaks and/or possible explosion.
- Do not dispose of batteries in fire.
- Do not mix old and new batteries.
- Do not mix alkaline, standard (carbon-zinc), or rechargeable (ni-cad, ni-mh, etc) batteries.

## ASSEMBLY

- BEFORE ASSEMBLY READ ALL INSTRUCTIONS CAREFULLY.
- ASSEMBLE UNIT ON A CLEAN, FLAT SURFACE.
- TOOL NEEDED: PHILLIPS HEAD SCREWDRIVER

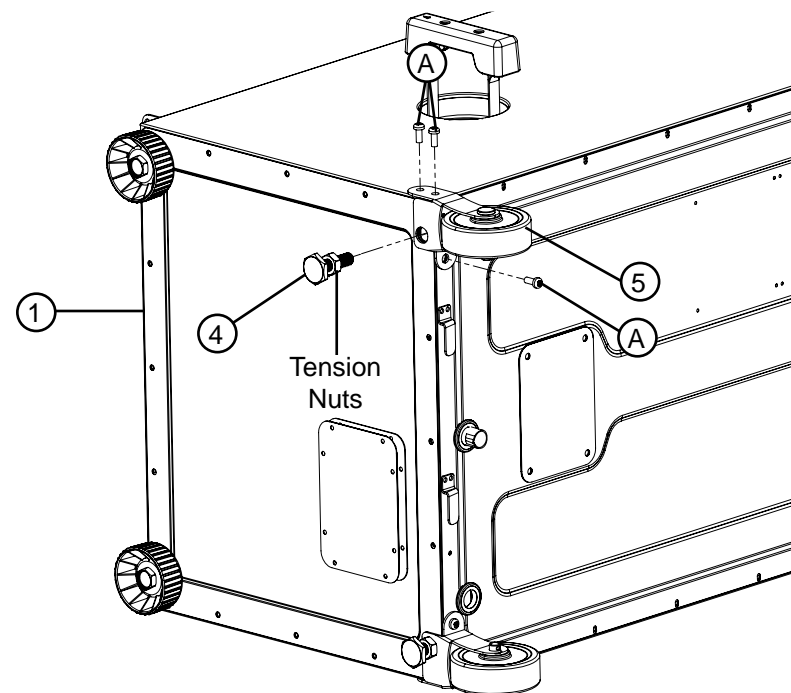

### STEP 1

Position wheel (5) on bottom of smoker body (1) as shown.

Insert adjustable screw leg (4) into bottom of wheel (5).

Secure wheel (5) to bottom of smoker body (1) using phillips screws (A).

Repeat step for opposite side.

Note: Set adjustable screw leg height by turning clockwise/counterclockwise so that smoker is level when unit is upright. Once level, secure back leg positions with attached tension nuts.

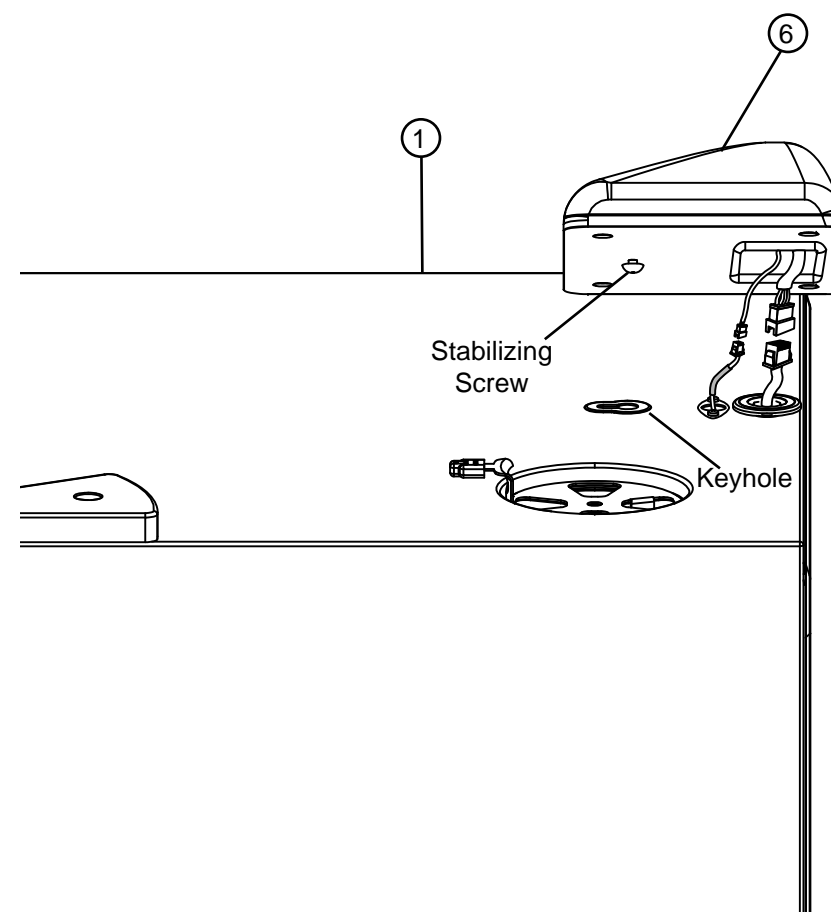

### STEP 2a

Position control panel (6) on top of smoker body (1) as shown.

Align slots on wire connector from control panel with tabs on wire connector on smoker as shown and connect together.

### STEP 2b

Mount control panel by inserting stabilizing screw head into keyhole.

Note: Stabilizing screw may need slight adjustment for snug fit.

## ASSEMBLY

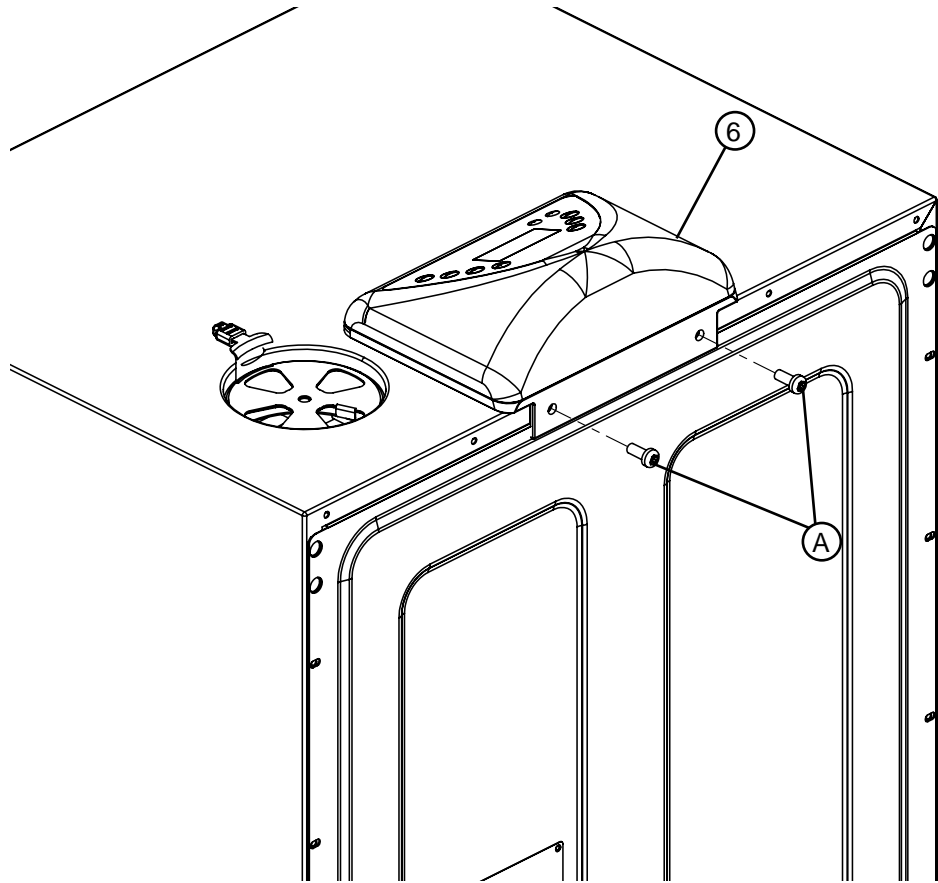

**STEP 3**  
Secure control panel (6) to smoker body (1) with Phillips screws (A).

Note: Do not over tighten.

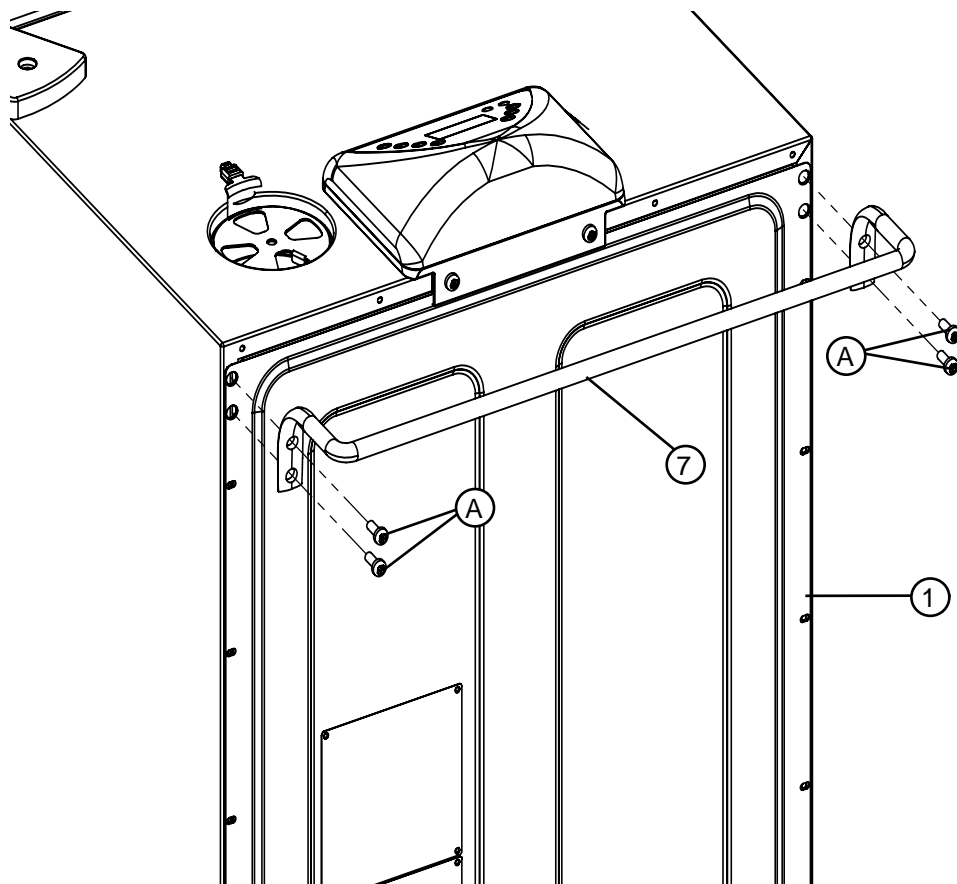

**STEP 4**  
Attach rear handle (7) to back of smoker body (1) using Phillips screws (A) as shown.

NOTE: Do not lift unit by rear handle.

## HOW TO USE CONTROL PANEL & REMOTE CONTROL

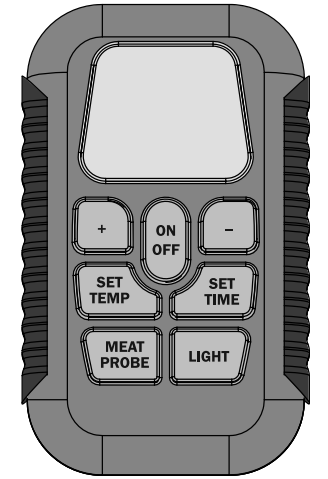
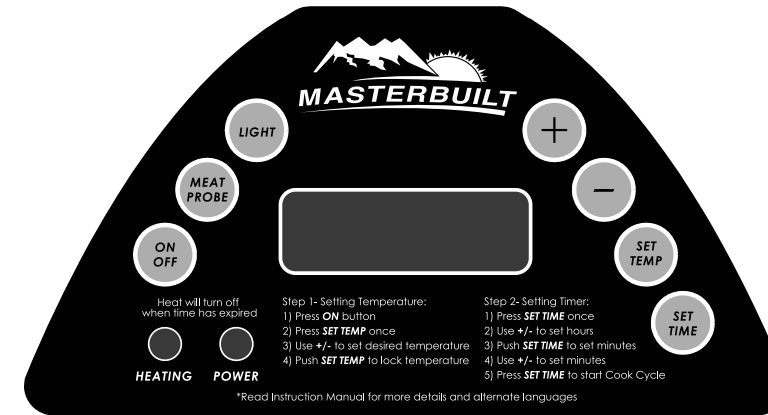

**Note:** Direct sunlight may interfere with ability to read LED display, block light if needed.

### To set temperature:

- Press ON button.
  - Press SET TEMP button once-LED display will blink.
  - Use +/- to set temperature.
  - Press SET TEMP button again to lock in temperature.
- Note: Heating will not begin until timer is set.

### To set timer:

- Press SET TIME button once-LED display for hours will blink.
- Use +/- to set hours.
- Press SET TIME button again to lock in hours. The minutes LED will start blinking.
- Use +/- to set minutes.
- Press SET TIME to lock in minutes and start cook cycle.

### Heat will turn off when time has expired.

### To use meat probe:

- Insert meat probe into center of meat to get most accurate reading.
- Press and hold MEAT PROBE button-LED display will show internal temperature of meat.
- Once MEAT PROBE button is released-LED display will return to set temperature or set time.

### To use light:

- Press LIGHT button to turn light on.
- Press LIGHT button to turn light off.

### To RESET control panel:

If control panel shows an error message, turn electric smoker off, unplug unit from outlet, wait ten seconds, plug unit back into outlet, then turn electric smoker on. This will reset control panel.

## PRESEASON INSTRUCTIONS

1. Make sure water pan is in place with NO WATER.
2. Set temperature to 275°F (135°C) and run unit for 3 hours.
3. Shut down and allow to cool. Some smoke may appear during this time, this is normal.
4. During last 45 minutes, add 1 cup of wood chips in chip loader to complete preseasoning.

### SMOKER IS READY TO USE

## HOW TO USE WOOD CHIP LOADER

Before starting unit, place 1 cup of wood chips in chip loader.

**Never use more than 1 cup of wood chips at a time. Never use wood chunks.**

Insert wood chip loader into smoker. Wood chips should be level with top rim of wood chip loader.

Turn handle to “Unload” mark on smoker. Wood will drop onto wood chip holder. Turn handle to “Load” and leave wood chip loader in place inside smoker.

Check wood chip holder periodically to see if wood has burned down by removing wood chip loader and looking into smoker through hole. Add more chips as needed.

Wood chip loader must be pulled out completely from smoker when checking wood chip level.

### ADDING MORE WOOD DURING SMOKING PROCESS:

**Caution:** Keep smoker door closed when adding wood chips.

**Note:** Wood chip loader will be HOT even if handle is not.

To add wood, turn handle to “Load” position on smoker.

Pull wood chip loader from smoker.

Place wood chips in wood chip loader and re-insert into smoker.

Turn handle to “Unload” mark on smoker. Wood will drop onto wood chip holder.

Temperature may spike briefly after wood is added. It will stabilize after a short time. Do not adjust temperature setting.



### CAUTION

When door is opened a flare up may occur. Should wood chips flare up, immediately close door, wait for wood chips to burn down then open door again. Do not spray with water.

## ASSEMBLY

### STEP 5

Slide cooking racks (13) onto guides inside smoker.

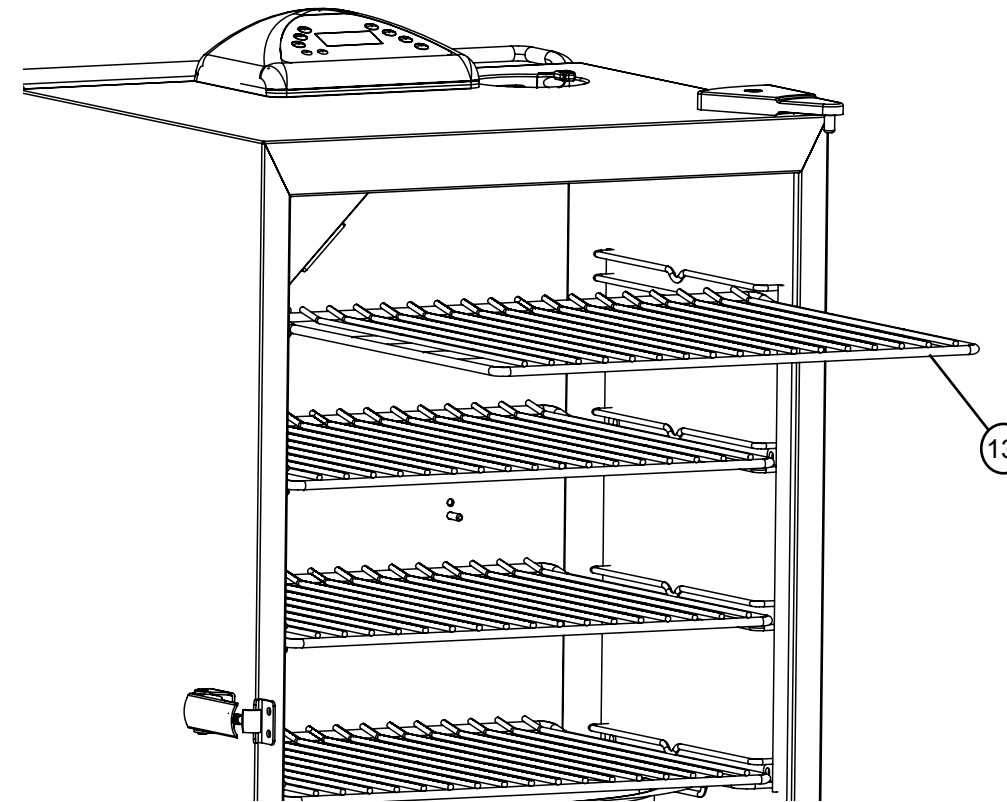

### STEP 6

Place water bowl (9) onto lower bracket inside smoker.

**Note:** Water bowl must always be in place during smoking process, even if there is no water or other liquid in bowl. Bowl will prevent food from dripping onto wood chip lid.

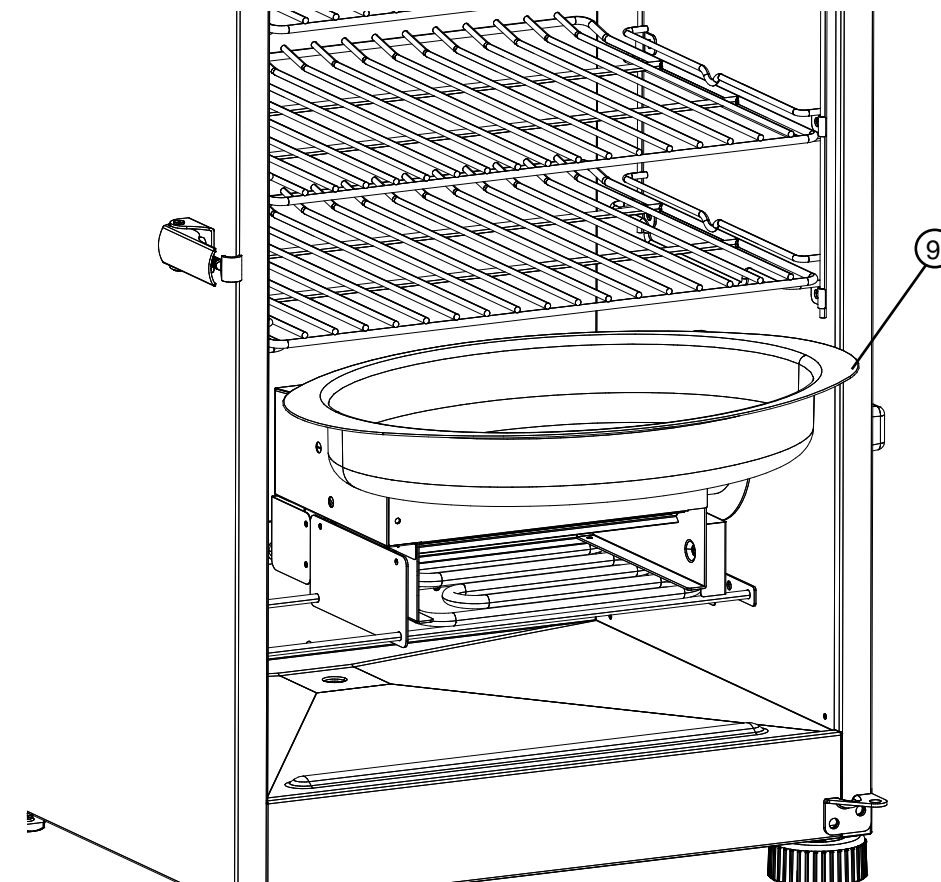

## ASSEMBLY

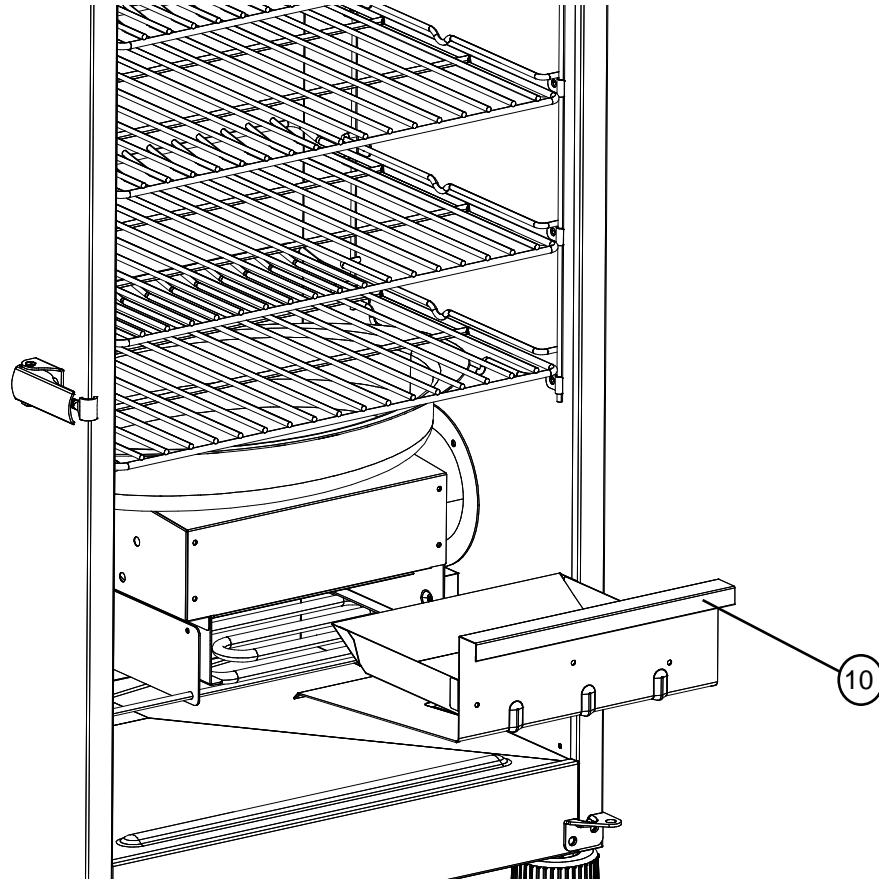

**STEP 7**  
Place wood chip tray (10) in smoker as shown.

Note: Wood chip holder and wood chip loader **MUST** be in place when using smoker. This minimizes the chance of flare ups.

## ASSEMBLY

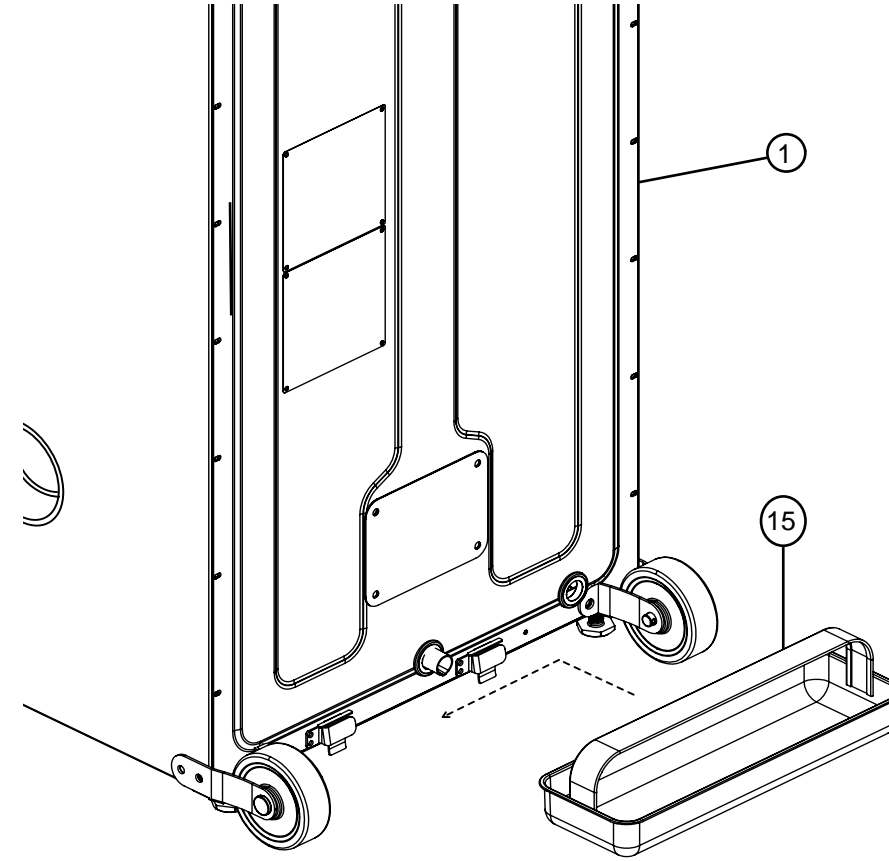

**STEP 9**  
Slide brackets on back of grease tray (15) onto tabs on back of smoker body (1) until grease tray stops.

Note: Wheels will not operate while grease tray is in place. Remove grease tray to push/pull smoker.

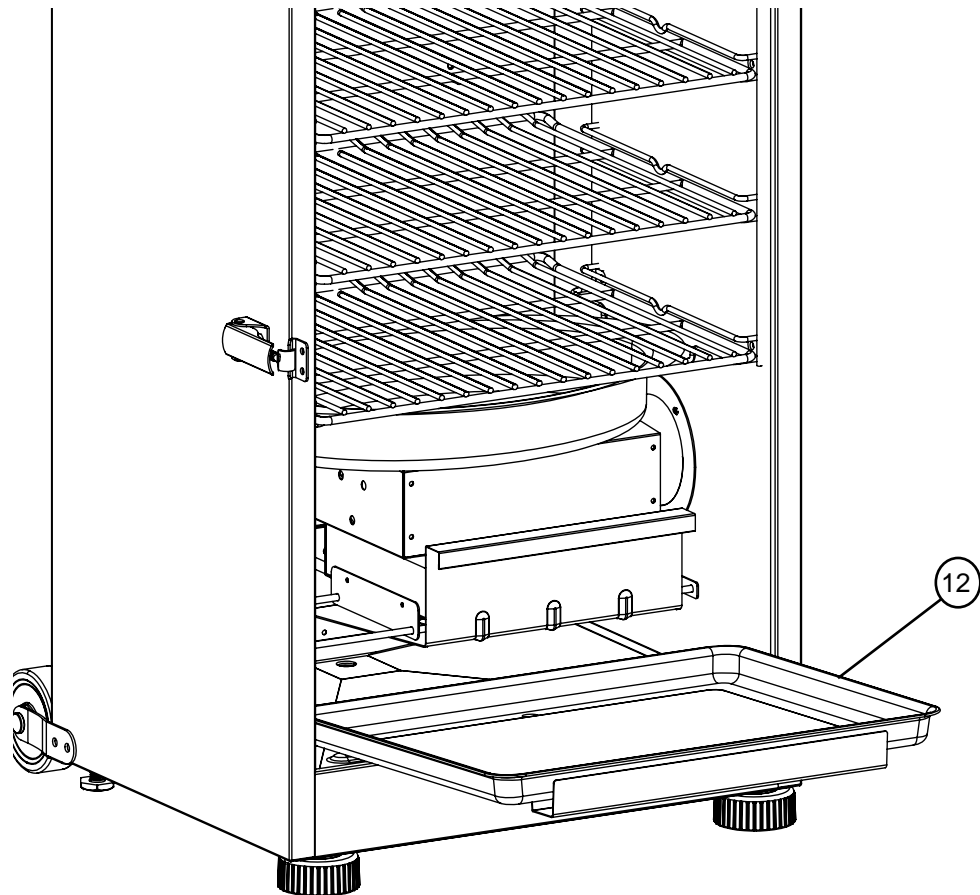

**STEP 8**  
Place drip pan (12) inside smoker below heating element as shown. Make sure drip pan hole aligns with hole in bottom of smoker.

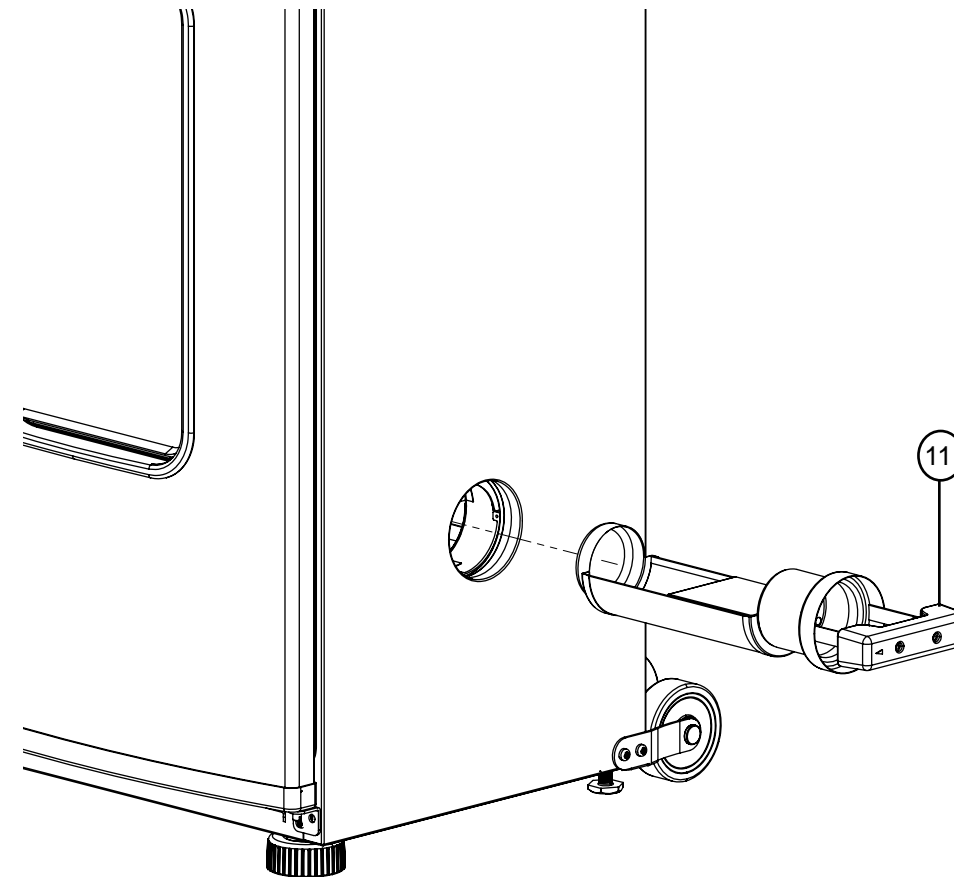

**STEP 10**  
Insert wood chip loader (11) into side of smoker as shown.