



Masterbuilt Manufacturing, Inc.  
 1 Masterbuilt Court  
 Columbus, Georgia 31907  
 Customer Service 1-800-489-1581





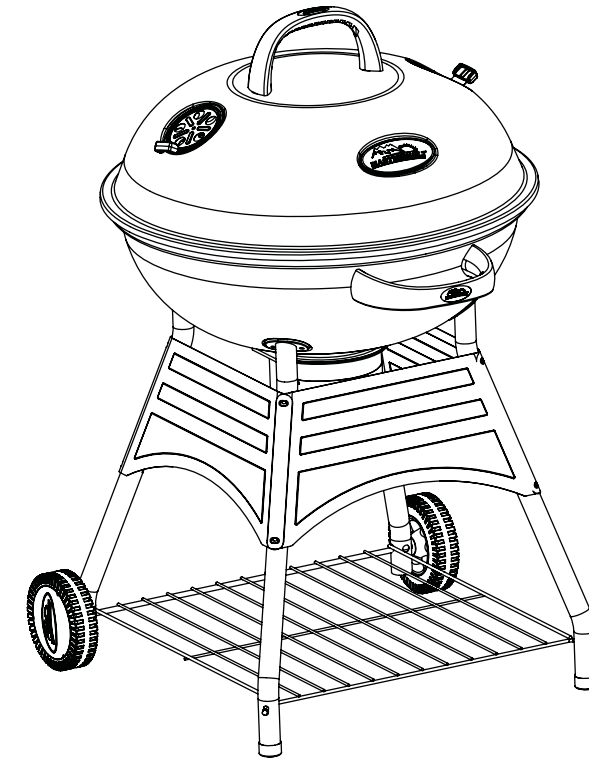

**ASSEMBLY, CARE & USE MANUAL**  
**WARNING & SAFETY INFORMATION**  
 MODELS 20041411, 20042811 KETTLE CHARCOAL GRILL  
 THIS PRODUCT IS FOR OUTDOOR USE ONLY

Manual Code: 9804100037 101110-JH20



Approximate assembly time: 25 minutes

Tools required for assembly: Adjustable Wrench, Phillips Head Screwdriver.

 <b>CARBON MONOXIDE HAZARD</b> 	 <b>WARNING</b> 
<p>Burning charcoal gives off carbon monoxide, which has no odor and can cause death.</p> <p><b>DO NOT</b> burn charcoal inside homes, vehicles, tents, garages or any enclosed areas.</p> <p>Use only outdoors where it is well ventilated.</p>	<p>This manual contains important information necessary for the proper and safe use of this grill.</p> <p>Read and follow all warnings and instructions before using grill and during use.</p> <p>Keep this manual for future reference.</p>
<p>Failure to follow these warnings and instructions properly could result in fire or explosion, which could cause property damage, personal injury, or death.</p>	



## GENERAL WARNING AND SAFETY INFORMATION



- Keep a fire extinguisher accessible at all times while operating grill.
- Never leave grill unattended while in use.
- Never use inside an enclosed area such as a patio, garage, building or tent.
- Never use inside a vehicle, not even a recreational vehicle such as a motor home, camper or truck bed.
- Never operate this grill under any overhead construction such as roof coverings, carports, awnings or overhangs.
- Maintain a minimum distance of 10 feet from all structures.
- Keep area clear of all combustible materials such as wood, dry plants, grass, brush, paper or canvas.
- Never operate this grill within 25 feet of flammable liquids.
- Never operate this grill within 10 feet of a gas cylinder.
- Never use this grill as a heater (READ CARBON MONOXIDE HAZARD).
- Use this grill only on a stable, level surface to prevent tipping.
- Use on non-combustible surfaces such as dirt, concrete, brick or rock.
- Keep children and pets away from grill at all times. Do not allow children to use grill.
- Only use charcoal lighting fluid. Never use gasoline, alcohol or other highly volatile fluids to ignite charcoal. These fluids can explode causing injury or death.
- Grill is HOT while in use and will remain HOT for a period of time afterwards. Do not touch any part of the grill without wearing protective gloves.
- Never move grill when in use. Allow grill to cool completely before moving or storing.
- Never leave HOT coals or ashes unattended.
- Do not store grill with HOT ashes or charcoal inside grill. Store only when fire is completely out and all surfaces are cold.
- Dispose of cold ashes by placing them in aluminum foil, soaking with water and discarding in a non-combustible container.
- Accessory attachments not supplied by Masterbuilt Manufacturing, Inc. are not recommended.
- Never use this product for anything other than its intended purpose. This grill is not for commercial use.
- Always use this grill in accordance with all applicable local, state and federal fire codes.



## WARNING



**Combustion by-product produced when using this product contains chemicals known to the State of California to cause birth defects, other reproductive harm, or cancer.**

**The materials used in this product may contain lead a chemical known to the State of California to cause birth defects and other reproductive harm.**

## LIMITED WARRANTY INFORMATION

Masterbuilt warrants its products to be free from defects in material and workmanship under proper assembly, normal use and recommended care for 90 days from the date of original retail purchase.

Masterbuilt warranty does not cover paint finish as it may burn off during normal use.

Masterbuilt warranty does not cover rust of the unit.

Masterbuilt requires reasonable proof of purchase for warranty claims and suggests that you keep your receipt. Upon the expiration of such warranty, all such liability shall terminate.

Within the stated warranty period, Masterbuilt, at its discretion, shall repair or replace defective components free of charge with owner being responsible for shipping. Should Masterbuilt require return of component(s) in question for inspection Masterbuilt will be responsible for shipping charges to return requested item.

This warranty excludes property damage sustained due to misuse, abuse, accident, damage arising out of transportation, or damage incurred by commercial use of this product.

*This expressed warranty is the sole warranty given by Masterbuilt and is in lieu of all other warranties, expressed or implied including implied warranty, merchantability, or fitness for a particular purpose.*

Neither Masterbuilt nor the retail establishment selling this product, has authority to make any warranties or to promise remedies in addition to or inconsistent with those stated above.

Masterbuilt's maximum liability, in any event, shall not exceed the purchase price of the product paid by the original consumer/ purchaser. Some states do not allow the exclusion or limitation of incidental or consequential damages. In such a case, the above limitations or exclusions may not be applicable.

**California residents only:** Notwithstanding this limitation of warranty, the following specific restrictions apply; if service, repair, or replacement of the product is not commercially practical, the retailer selling the product or Masterbuilt will refund the purchase price paid for the product, less the amount directly attributable to use by the original buyer prior to the discovery of the nonconformity. Owner may take the product to the retail establishment selling this product in order to obtain performance under warranty.

This expressed warranty gives you specific legal rights, and you may also have other rights which vary from state to state.

Go Online [www.masterbuilt.com](http://www.masterbuilt.com)

or complete and return to

Attn: Warranty Registration

Masterbuilt Mfg. Inc.

1 Masterbuilt Court - Columbus, GA 31907

Name: \_\_\_\_\_

Address: \_\_\_\_\_

City, State/Province, Postal Code: \_\_\_\_\_

Phone Number: \_\_\_\_\_ E-Mail Address: \_\_\_\_\_

Model Number: \_\_\_\_\_ Serial Number: \_\_\_\_\_

Purchase Date: \_\_\_\_\_ Place of Purchase: \_\_\_\_\_

## RECIPES

### BBQ BURGERS

¼ cup catsup  
2 tbsp steak sauce  
1 tbsp water  
1 tsp sugar  
1 tsp vinegar  
1 clove garlic, minced  
1 lb lean ground beef  
¼ tsp salt  
¼ tsp black pepper  
4 hamburger buns, split and toasted

For sauce, in small saucepan combine catsup, steak sauce, water, sugar, vinegar, garlic, and if desired, hot pepper sauce. Bring to boiling, and reduce heat. In a medium bowl combine ground beef, salt, and pepper. Shape meat mixture into four ¾ inch thick patties.

Grill patties on the rack of an uncovered grill directly over medium coals for 14-18 minutes or until meat reaches 160° F degrees internally. Turn patties once during cooking and brush once or twice with sauce during the last five minutes. Serve burgers on buns.

Optional: few dashes bottled hot pepper sauce, American cheese slices, lettuce leaves, tomato slices, onion slices, and pickle slices.

### HERB-MUSTARD CHICKEN QUARTERS

2 tbsp creamy Dijon-style mustard blend  
1 tbsp snipped fresh parsley  
1 tbsp snipped fresh oregano or 1 tsp dried oregano crushed  
1 tbsp water  
1/8 tsp ground red pepper  
3 to 3 ½ lb whole broiler-fryer chicken, cut into quarters

For sauce, in a small bowl combine mustard, parsley, oregano, water and red pepper. Cover and chill until ready to use. Optional to remove skin.

Place chicken bone side down. Cover and grill for 50-60 minutes or until chicken is no longer pink. (170° F degrees for breast and 180° F degrees for dark meat). Brush the pieces with sauce occasionally during the last 10 minutes of grilling.

### TANGY PEANUT-SAUCE RIBS

4 lbs meaty pork spareribs or pork loin back ribs  
¼ cup hot water  
¼ cup peanut butter  
2 tbsp lime juice  
2 tbsp sliced green onion  
½ tsp grated fresh ginger or ¼ tsp ground ginger  
¼ tsp ground red pepper

Trim fat from ribs. Cut ribs into 4-6 serving size pieces. Place ribs bone side down. Cover and grill for 1 to 1 ¾ hours or until tender. Meanwhile, for sauce, in a small saucepan gradually stir hot water into peanut butter (mixture will stiffen at first). Stir in lime juice, green onion, ginger, and red pepper. Cook and stir over low heat until heated through. Spoon sauce over ribs.

### CAJUN HALIBUT

Relish  
1 can (7 oz) Green Giant Niblets whole kernel corn, drained  
1 medium tomato, chopped  
2 medium green onions, chopped (2 tbsp)  
1 tablespoon cider vinegar  
2 tsp honey  
¾ tsp dried oregano leaves  
¼ tsp ground red pepper (cayenne)  
¼ tsp salt

Fish  
4 halibut steaks (about 6 oz each)  
2 tbsp Worcestershire sauce  
½ tsp coarse ground pepper  
¼ tsp dried oregano leaves

In small bowl, mix all relish ingredients; set aside. Brush halibut with Worcestershire sauce; sprinkle with pepper and oregano. Cover and grill fish over medium heat 10-15 minutes, turning once or twice, until fish flakes easily with fork. Serve fish with relish.

## PARTS LIST

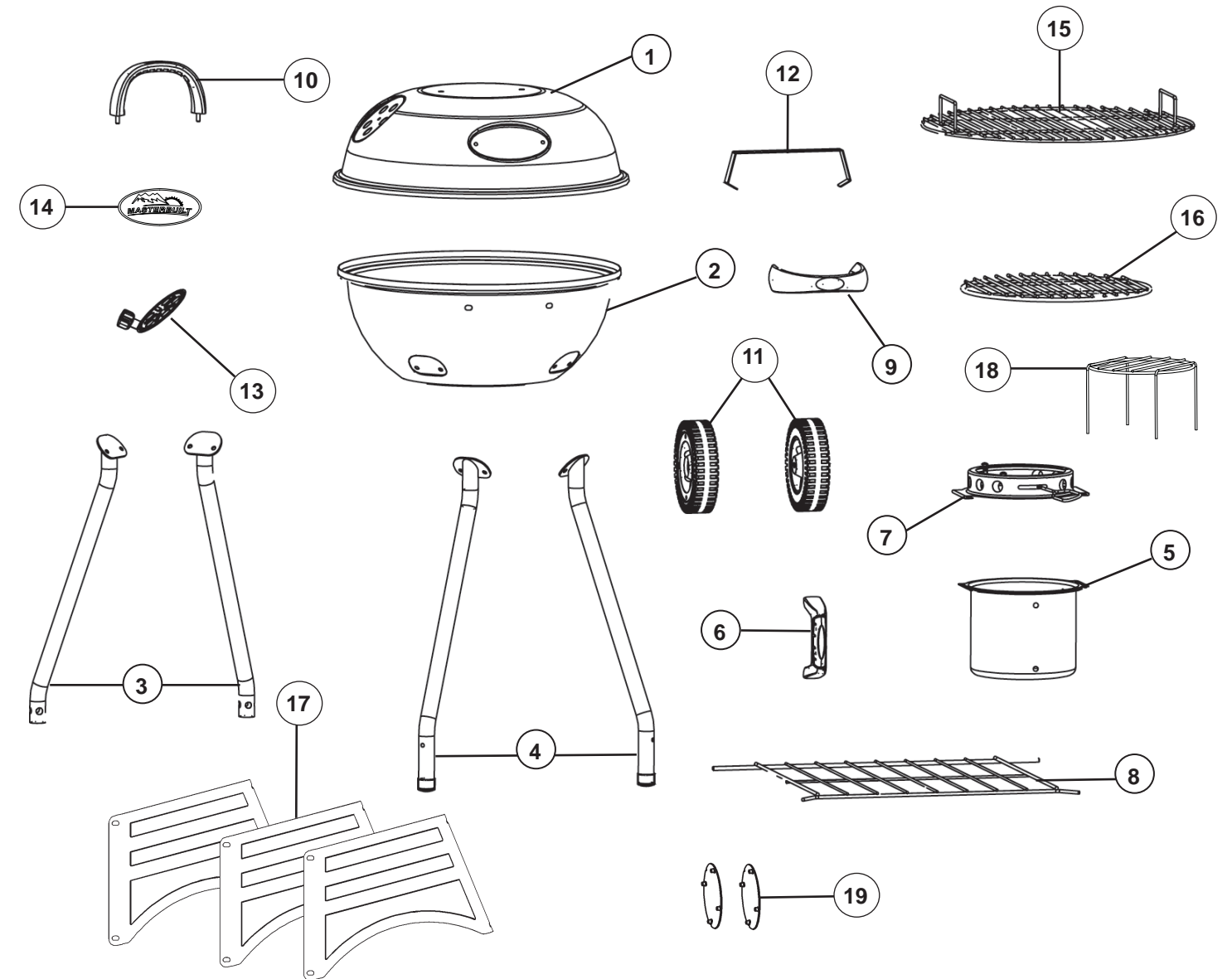

ITEM NO	QUANTITY	DESCRIPTION	ITEM NO	QUANTITY	DESCRIPTION
1	1	Kettle Lid	10	1	Lid Handle
2	1	Kettle Base	11	2	Wheels
3	2	Short Legs	12	1	Lid Hook
4	2	Long Legs	13	2	Air Damper
5	1	Ash Can	14	1	Logo Plate (pre-assembled)
6	1	Ash Can Handle	15	1	Cooking Grate
7	1	Ash Can Spacer Ring w/Air Dampers	16	1	Charcoal Grate
8	1	Storage Shelf	17	3	Skirt Panel
9	1	Base Handle	18	1	Charcoal Lighting Grate
			19	2	Hub Caps

## HARDWARE LIST



**(A)**  
1/4-20x1/2"  
Phillips Head Screw  
qty-8



**(B)**  
3/16-24x3/8"  
Phillips Head Screw  
qty-5



**(C)**  
3/16"  
Hex Lock Nut  
qty-5



**(D)**  
1/4-20  
Serrated Flange Nut  
qty-22



**(E)**  
5/16"  
Nylon Hex Lock Nut  
qty-2



**(F)**  
1/4"  
Aluminum Flat Washer  
qty-6

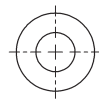

**(G)**  
5/16"  
Aluminum Flat Washer  
qty-10



**(H)**  
Heat Insulation Washer  
qty-6

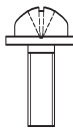

**(I)**  
1/4-20x1 3/4"  
Phillips Head Screw  
qty-8



**(J)**  
1/4"  
Lock Washer  
qty-2



**(K)**  
1/4"  
Crown Nut  
qty-2

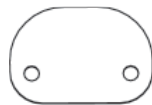

**(L)**  
Heat Insulation Washer  
qty-4

## APPROXIMATE GRILLING TIMES

BEEF	SIZE	GRILLING TIME	INTERNAL TEMP
Steaks	3/4" (2cm) thick	3 to 4 min. /side	med rare 145°F (62°C)
		4 to 5 min. /side	med 160°F (71°C)
Kabobs	1" (2.5cm) cubes	3 to 4 min. /side	145°-160°F (62-71°C)
Hamburger patties	1/2" (12mm) thick	3 to 4 min. /side	med 160°F (71°C))
Roast, rolled rump	4-6 lbs. (1.8-2.7kg)	18 to 22 min /lb.	145°-160°F (62-71°C)
Sirloin tip	3 1/2-4 lbs. (1.5-1.8kg)	20 to 25 min. /lb.	145°-160°F (62-71°C)
Ribs, back	cut in 1-rib portions	10 min. /side	med 160°F (71°C)
	half, 2-3 lbs. (0.9-1.3kg)	10 to 12 min. /side	med rare 145°F (62°C)
Tenderloin	whole, 4-6 lbs. (1.8-2.7kg)	12 to 15 min. /side	med 160°F (71°C)
PORK	SIZE	GRILLING TIME	INTERNAL TEMP
Chops, bone-in	3/4" (2cm) thick	3 to 4 min. /side	med 160°F (71°C)
Chops, bone-out	1 1/2" (4cm) thick	7 to 8 min. /side	med 160°F (71°C)
Tenderloin	1/2-1 1/2 lbs. (0.2-0.6kg)	15 to 25 min. total	med 160°F (71°C)
Ribs (indirect heat)	2-4 lbs. (0.9-1.8kg)	1 1/2 to 2 hrs.	med 160°F (71°C)
VENISON	SIZE	GRILLING TIME	INTERNAL TEMP
Roast, saddle or leg	6-7 lbs. (2.7-3.1kg)	25 to 30 min. /lb.	145°-160°F (62-71°C)
Steaks	3/4" (2cm) thick	6 to 7 min. /side	med 160°F (71°C)
CHICKEN	SIZE	GRILLING TIME	INTERNAL TEMP
Broiler fryer (indirect heat)	3-4 lbs. (1.3-1.8kg)	60 to 75 min.	in thigh 180°F (82°C)
Cornish hens	18-24 oz. (510-680g)	45 to 55 min.	in thigh 180°F (82°C)
Breast halves, bone-in	6-8 oz. ( 170-226g) each	10 to 15 min. /side	170°F (77°C)
Breast halves, boneless	4 oz. (113g) each	6 to 8 min. /side	170°F (77°C)
Legs or thighs	4-8 oz. (113-226g)	10 to 15 min. /side	180°F (82°C)
Drumsticks	4 oz. (113g)	8 to 12 min. /side	180°F (82°C)
Wings	2-3 oz. (56-85g)	8 to 12 min. /side	180°F (82°C)

- When outside temperature is cooler than 65°F and/or altitude is above 3,500 feet, additional cooking time may be required. To insure that meat is completely cooked use a meat thermometer to test internal temperature.

- Lifting grill lid during cooking process may extend cooking time due to heat loss.

## FREQUENTLY ASKED QUESTIONS REGARDING CHARCOAL GRILLS

### Q. My cooking grate has rust. How do I get rid of it?

Seasoning will prevent rust and food from sticking. Season by applying a thin coating of solid vegetable shortening over the entire surface. Place cooking grate in grill and allow to heat for 1 to 1-1/2 hours. Grate is now ready to use. Frequent re-seasoning prevents rusting. If rust occurs, clean with a steel brush. Reapply vegetable shortening and heat as indicated above.

### Q. When can I put my meat on the grill?

Grill is ready for use when charcoal is ashed over and no visible flames are present.

### Q. How long will the briquets stay hot?

If cooking for more than 30 to 40 minutes, additional briquets must be added to the fire. Add 10 or 12 briquets to the outer edge of the fire immediately after it has been spread. Once these coals become 80% ashed over, add to the center of the fire as needed to maintain constant cooking temperature. Read all instructions and warnings on charcoal bag.

### Q. Can adjusting the air damper on my grill make a difference?

Dampers on a covered grill are usually left open. This allows oxygen into the grill, increasing the temperature of the coals. Regulate the grill temperature by adjusting the air dampers. Closing them (either partially or completely) may help to "cool down" a fire that is too hot.

## SAFE STORAGE AND MAINTENANCE

- Inspect hardware and assembled parts on a regular basis to insure grill is in safe working condition.
- ALWAYS allow grill to cool completely before handling.
- ALWAYS empty ash can after use only when ashes have completely cooled. This will help prolong ash can life.
- Clean grill, including special surfaces such as cooking grates with mild cleaning agents. Wipe outside of grill with damp rag. DO NOT use oven cleaner.
- ALWAYS cover and store cold grill in a protected area.
- Indoor storage of grill is permissible only if the charcoal has burned to a complete ash AND is cold. Remember to remove cold ashes before storing.
- Grill is made of steel and may rust over time. If rusting occurs on outside surfaces, clean area with sand paper or steel wool, then cover with heat resistant paint, except for stainless steel parts.
- If rusting occurs on the inside surface of grill, clean area with sandpaper or steel wool, then coat with cooking oil, except for stainless steel parts.
- NEVER USE PAINT ON INSIDE SURFACES OF GRILL.



DO NOT RETURN TO RETAILER  
For Assembly Assistance, Missing or Damaged Parts  
Call: MASTERBUILT Customer Service at 1-800-489-1581 or  
EMAIL us at Customerservice@masterbuilt.com.

## REPLACEMENT PARTS LIST

MODEL# 20041411	MODEL# 20042811	DESCRIPTION
PART NUMBER		
9904090048	9904090048	Short Leg Kit
9904090049	9904090049	Long Leg Kit
9904090050	9904090050	Kettle Lid Kit
9904090051	9904090051	Kettle Base Kit
9904090052	9904090052	Ash Can Handle Kit
9904100017	9904100017	Storage Shelf Kit
990060087	990060087	Wheel Kit
9904090045	9904090045	Lid Handle Kit
9904090046	9904090046	Base Handle Kit
990060095	990060095	Lid Air Damper Kit
990000004	990000004	Revolution Lid Hook Kit
9904100020	9904100022	Logo Plate Kit
990060130	990060130	Ash Can Spacer Ring Kit
9004100031	9004100031	Charcoal Lighting Grate
909060030	909060030	Ash Can w/o Dampers
909060028	909060028	Air Damper Ring Control Handle w/Nut
9004090081	9004090081	Cooking Grate
906060050	906060050	Charcoal Grate
9004090011	9004090011	MB Hub Cap
9904090058	9904090058	Skirt Panel
9804100037	9804100037	Instruction Manual
9904100019	9904100019	Hardware Kit

## ASSEMBLY INSTRUCTIONS

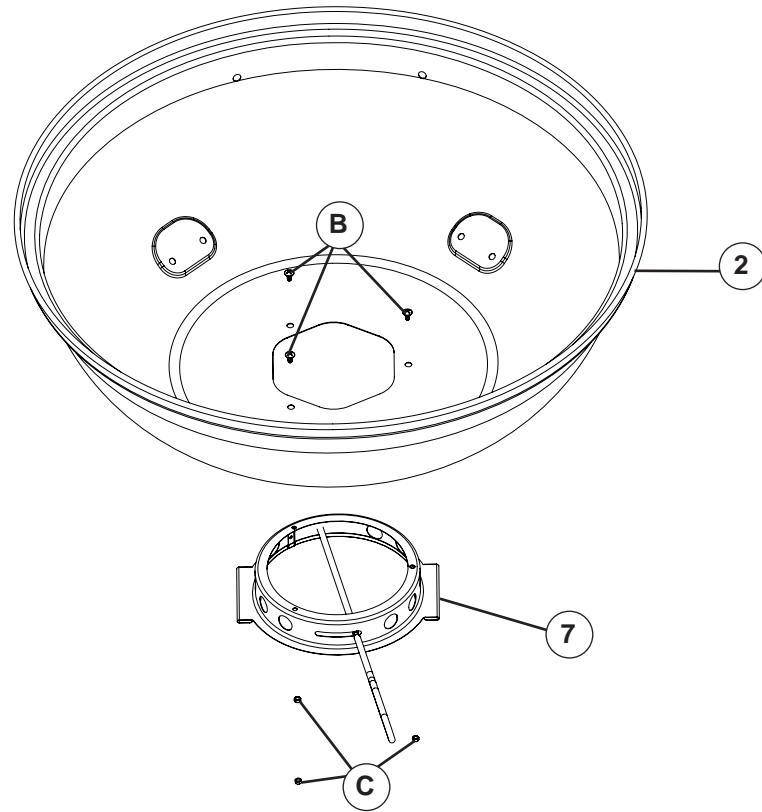

Before assembly read instructions carefully.

### Tools needed for assembly:

Adjustable Wrench  
Phillips Head Screwdriver

Assemble grill on a clean, flat surface.

### STEP 1.

Align ash can spacer ring (7) with holes in kettle base (2). Insert Phillips head screw (B) through kettle base (2) into ash can spacer ring (7) as shown. Secure with hex lock nut (C).

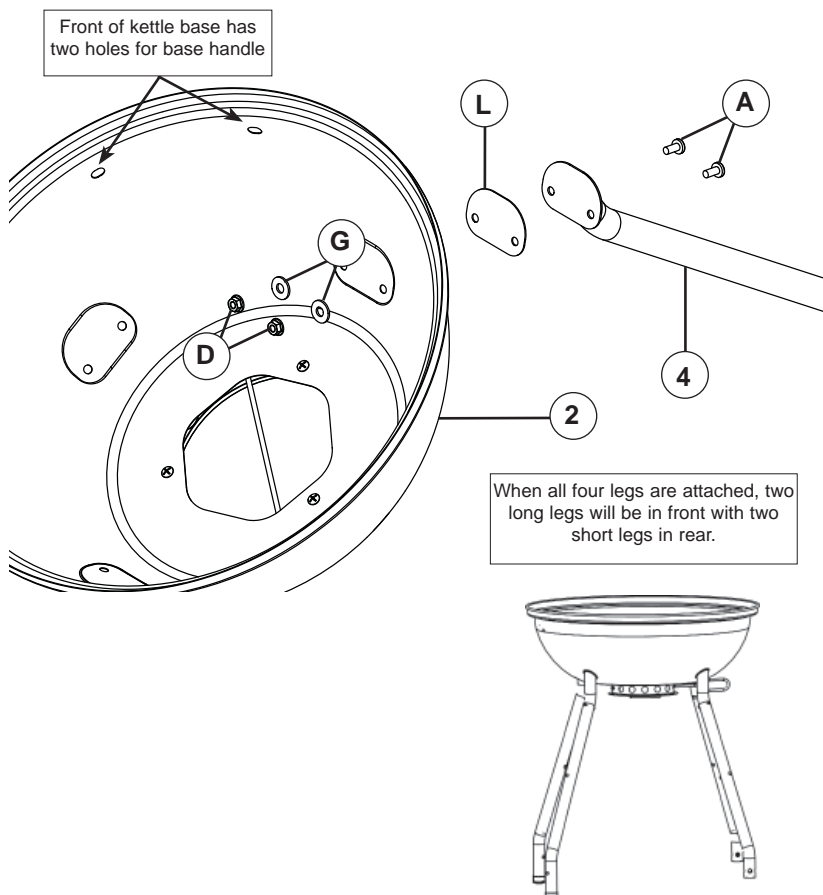

**Do not tighten screws all the way. Legs may need to be adjusted when storage shelf is attached in STEP 3.**

### STEP 2.

Place heat insulation washers (L) on long legs (4) as shown. Align holes in long legs with holes in kettle base (2). Insert Phillips head screws (A) through holes on legs. Secure with aluminum flat washers (G) and serrated flange nuts (D).

Repeat step with short legs on rear side of kettle base.

## GRILL OPERATION CAUTIONS

- Avoid bumping or impacting grill.
- Keep your hands, hair and face away from burning charcoal.
- This grill has an open flame. Be careful of loose hair and clothing during operation. They may catch fire.
- Use protective gloves when handling this grill or working with fire. Use protective gloves or long, sturdy fireplace tools when adding wood or charcoal.
- Do not allow anyone to conduct activities around this grill during or following its use until the unit has cooled. This grill is HOT during operation and remains HOT for a period of time following its use.
- Fatty foods like hamburgers can have excess grease that can cause flare ups. When cooking fatty foods, use caution when opening lid and during cooking to avoid being burned.
- Be careful when removing food from grill. All surfaces are HOT and may cause burns. Use protective gloves or long, sturdy cooking tools.
- Never use glass, plastic or ceramic cookware on this grill.
- The use of alcohol, prescription or non-prescription drugs may impair the user's ability to properly assemble or safely operate this grill.
- Grill lid and base are HOT while in use and during cooling process.
- Do not remove ash can while ashes and charcoal are HOT.
- Air dampers are HOT while the grill is in use and during cooling; wear protective gloves when adjusting.
- Never overfill charcoal grate. This can cause serious injury as well as damage the unit.
- Only use charcoal lighting fluid, never use gasoline, alcohol or other highly volatile fluids to ignite the charcoal. These fluids can explode causing injury or death.

REMINDER: NEVER OPERATE THIS GRILL UNDER ANY OVERHEAD CONSTRUCTION. MAINTAIN A MINIMUM DISTANCE OF 10 FT (3M) FROM OVERHEAD CONSTRUCTION, WALLS OR RAILS. SEE DIAGRAM BELOW.

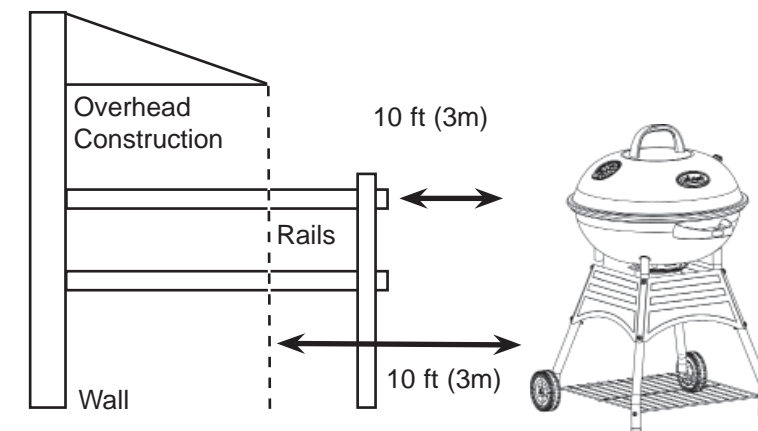

## HOW TO USE QUICK START IGNITION SYSTEM

Read all instructions and warnings on charcoal bag and in manual before using.

1. Load three crumpled sheets of newspaper on top of grate inside ash can. Place ash can in position below grill.
  2. Pile charcoal directly above ash can on charcoal grate. Open holes in bottom air damper, and ignite paper in ash can.
  3. Spread charcoal out on grate and cook in as little as 20 minutes.
- NEVER USE GASOLINE TO LIGHT CHARCOAL.
  - OVERFILLING CHARCOAL GRATE CAN CAUSE SERIOUS INJURY AND DAMAGE THE UNIT.
  - NEVER ADD ADDITIONAL LIGHTER FLUID ONCE CHARCOAL HAS IGNITED.
  - HOT COALS SHOULD NOT BE LEFT UNATTENDED.
  - GRILL IS HOT. USE PROTECTIVE GLOVES AND LONG, STURDY COOKING UTENSILS.

### WARNING

To ensure that it is safe to eat, food must be cooked to the minimum internal temperatures listed in the table below.

USDA* Safe Minimum Internal Temperatures	
Fish	145° F
Pork	160° F
Egg Dishes	160° F
Steaks and Roasts of Beef, Veal or Lamb	145° F
Ground Beef, Veal or Lamb	160° F
Whole Poultry (Turkey, Chicken, Duck, etc.)	165° F
Ground or Pieces Poultry (Chicken Breast, etc.)	165° F

\* United States Department of Agriculture

## ASSEMBLY INSTRUCTIONS

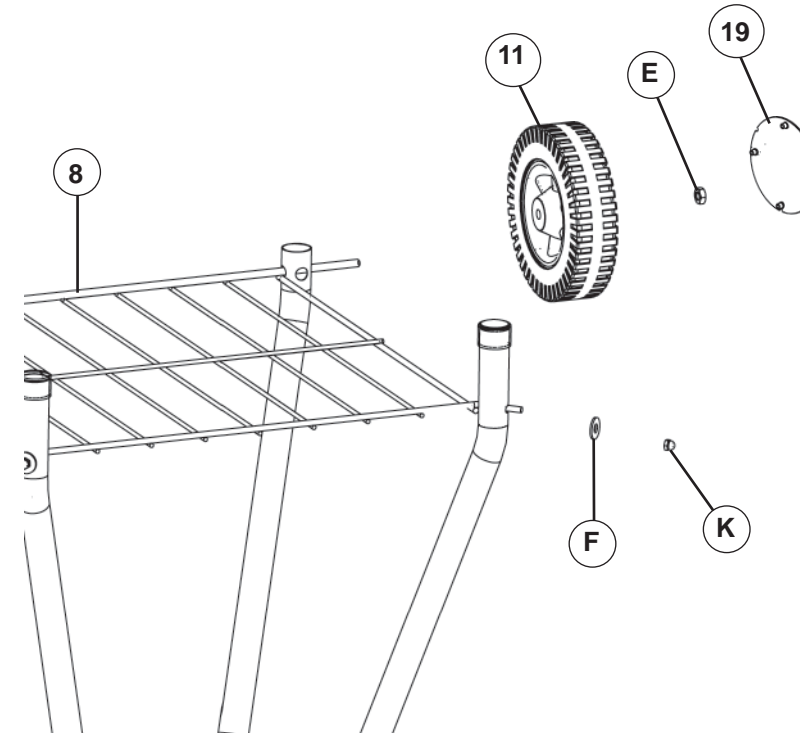

Carefully reposition grill as shown. Be careful not to chip/scratch porcelain.

### STEP 3.

**Note:** Shelf may require tilting to place in position. Legs may need to be spread apart to place shelf in position.

Insert storage shelf (8) into holes in grill legs as shown. Secure storage shelf to long legs using aluminum flat washer (F) and crown nut (K).

Attach one wheel (11), indented side out, to each short leg. Then secure wheels and storage shelf to legs using nylon hex lock nuts (E).

Snap hubcaps (19) in place as shown.

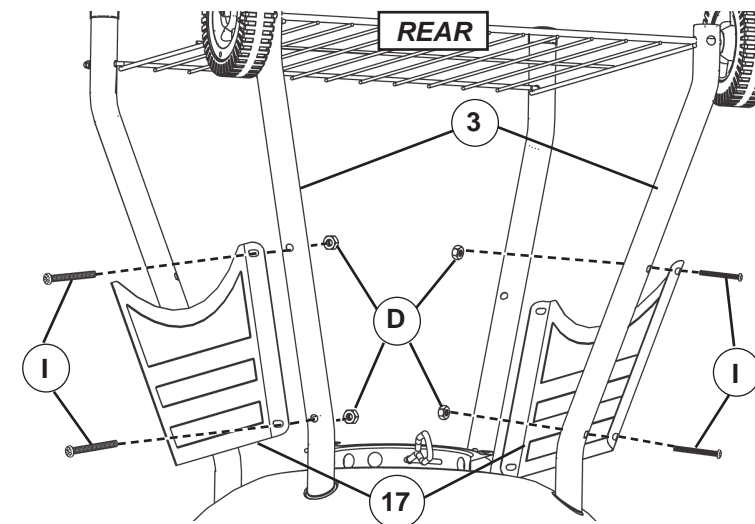

**Do not tighten skirt panel bolts until full panel attachment is complete.**

### STEP 4a.

Align holes in skirt panel (17) with holes in short leg (3) on right side. Insert screws (I) through holes in skirt panel (17) into short leg (3) as shown. Attach nuts (D). Do not tighten.

Repeat on left side for remaining short leg.

### STEP 4b.

On front of grill overlap last skirt panel (17) so it overlaps front edges of panels on left and right.

Secure all panels to front legs (4) with screws (I) and serrated flange nuts (D).

**Tighten all leg screws and nuts at this time.**

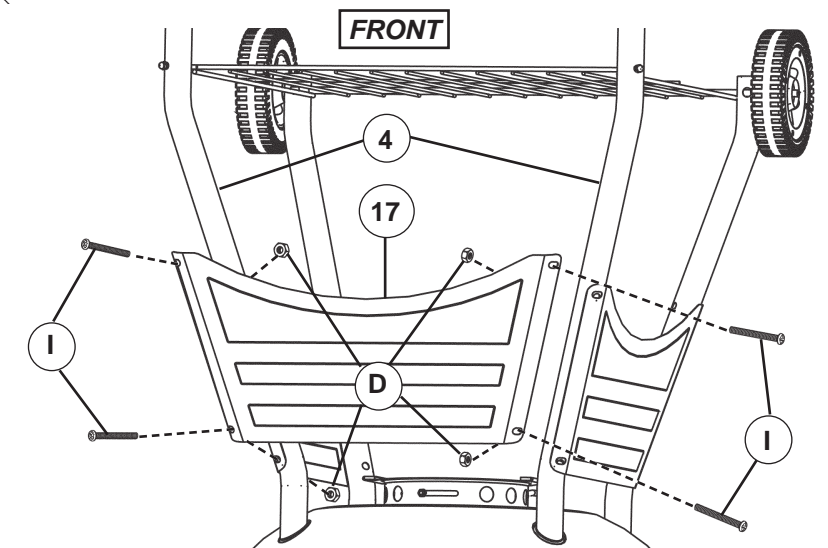

## ASSEMBLY INSTRUCTIONS

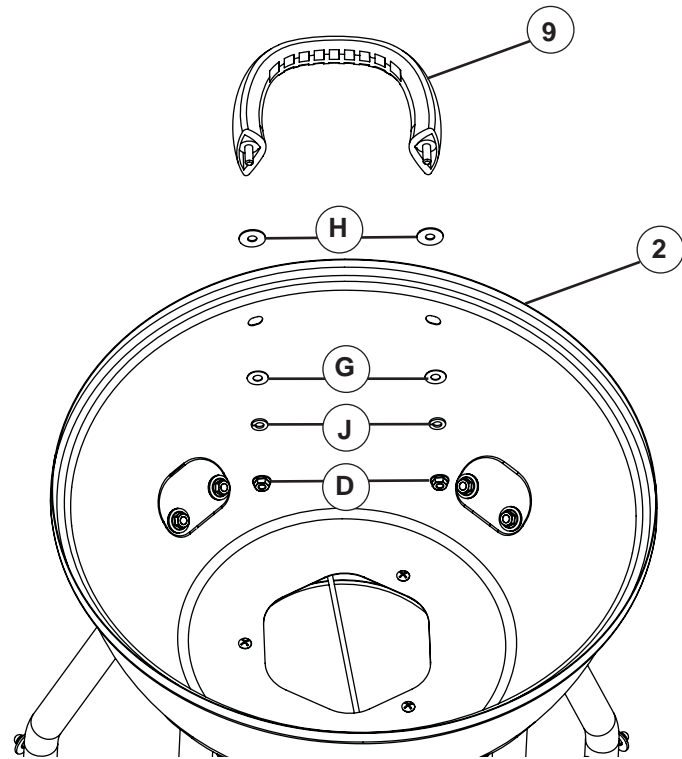

Carefully reposition grill as shown.

### STEP 5.

Place heat insulation washers (H) on base handle (9) as shown. Insert base handle (9) into kettle base (2). Secure with aluminum flat washers (G) lock washers (J) and serrated flange nuts (D).

## ASSEMBLY INSTRUCTIONS

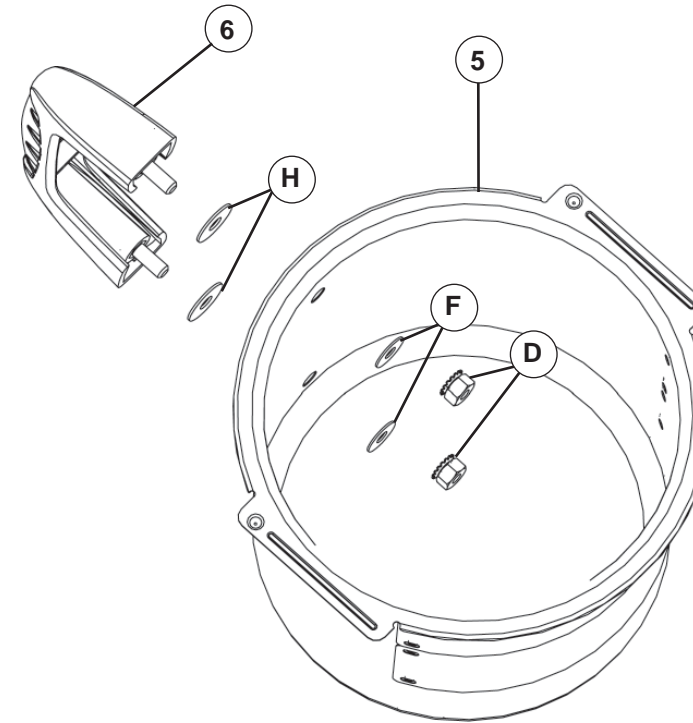

### STEP 7.

Place heat insulation washers (H) on ash can handle (6) as shown. Insert ash can handle (6) into ash can (5) and secure using aluminum flat washers (F) and serrated flange nuts (D).

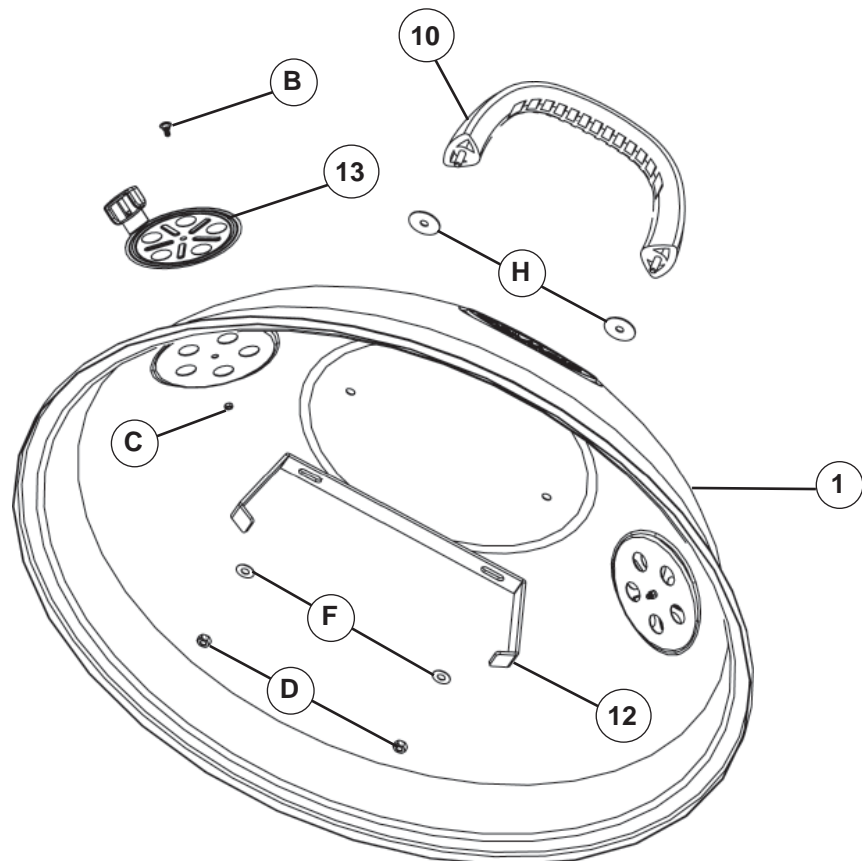

### STEP 6a.

Place heat insulation washers (H) on lid handle (10) as shown. Insert lid handle (10) into holes in kettle lid (1). Add lid hook (12) then aluminum flat washers (F) and secure with serrated flange nuts (D).

### STEP 6b.

**Note:** Do not over tighten. Damper should move freely.

Attach air damper (13) to kettle lid (1) using phillips head screw (B) and hex lock nut (C).

Repeat on opposite side for remaining air damper.

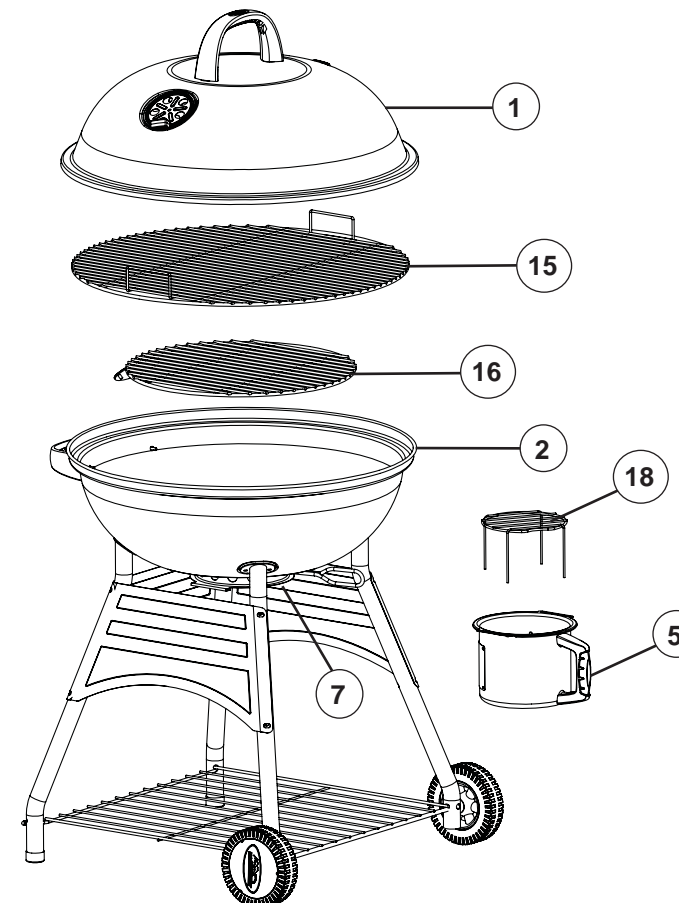

### STEP 8.

Insert charcoal lighting grate (18) into assembled ash can (5) as shown below.

Slide assembled ash can (5) onto guides of ash can spacer ring (7).

Place charcoal grate (16) inside kettle base (2).

Rest cooking grate (15) on kettle base (2) as shown.

Place kettle lid (1) onto kettle base (2).

**GRILL IS READY FOR USE**