

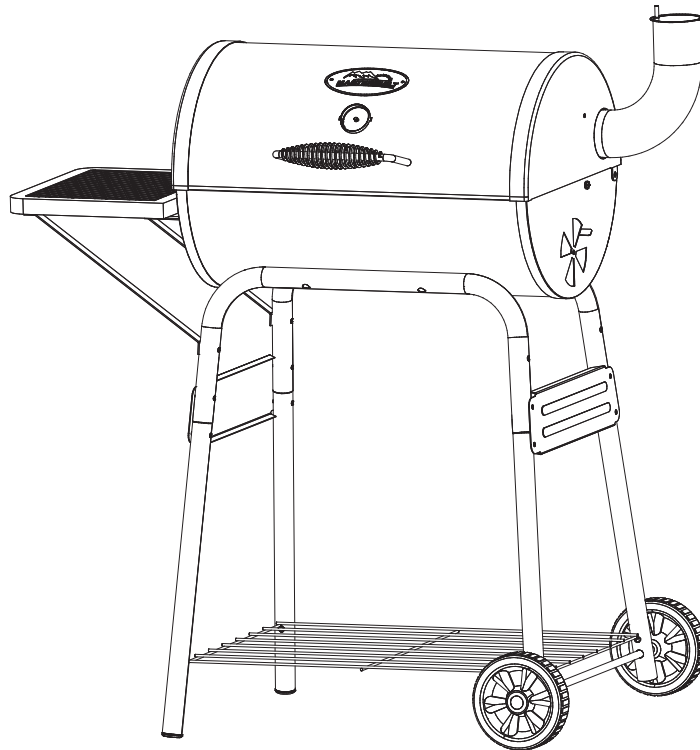





**ASSEMBLY, CARE & USE MANUAL
 WARNING & SAFETY INFORMATION
 MODEL: 20040411 BARREL GRILL
 THIS PRODUCT IS FOR OUTDOOR USE ONLY**

Manual Code: 9804100059 120110-04JH



Tools required for assembly: Adjustable Wrench, Phillips Head Screwdriver.

 CARBON MONOXIDE HAZARD 	 WARNING 
<p>Burning charcoal gives off carbon monoxide, which has no odor and can cause death.</p> <p>DO NOT burn charcoal inside homes, vehicles, tents, garages or any enclosed areas.</p> <p>Use only outdoors where it is well ventilated.</p>	<p>This manual contains important information necessary for the proper and safe use of this grill.</p> <p>Read and follow all warnings and instructions before using grill and during use.</p> <p>Keep it for future reference.</p>
<p>Failure to follow these warnings and instructions properly could result in fire or explosion, which could cause property damage, personal injury, or death.</p>	



GENERAL WARNING AND SAFETY INFORMATION



- Keep a fire extinguisher accessible at all times while operating grill.
- Never leave grill unattended while in use.
- Never use inside an enclosed area such as a patio, garage, building or tent.
- Never use inside a vehicle, not even a recreational vehicle such as a motorhome, camper, or truck bed.
- Never operate this grill under any overhead construction such as roof coverings, carports, awnings or overhangs.
- Maintain a minimum distance of 10 ft. (3m) from all structures.
- Keep area clear of all combustible materials such as wood, dry plants, grass, brush, paper or canvas.
- Never operate this grill within 25 ft. (7.5m) of flammable liquids.
- Never operate this grill within 10 ft. (3m) of a gas cylinder.
- Never use this grill as a heater (READ CARBON MONOXIDE HAZARD).
- Use this grill only on a stable, level surface to prevent tipping.
- Use on non-combustible surfaces such as dirt, concrete, brick or rock.
- Keep children and pets away from grill at all times. Do not allow children to use grill.
- Only use charcoal lighting fluid. Never use gasoline, alcohol or other highly volatile fluids to ignite charcoal. These fluids can explode causing injury or death.
- Grill is HOT while in use and will remain HOT for a period of time afterwards. Do not touch any part of the grill without wearing protective gloves.
- Never move grill when in use. Allow grill to cool completely before moving or storing.
- Never leave HOT coals or ashes unattended.
- Do not store grill with HOT ashes or charcoal inside grill. Store only when fire is completely out and all surfaces are cold.
- Dispose of cold ashes by placing them in aluminum foil, soaking with water and discarding in a non-combustible container.
- Accessory attachments not supplied by Masterbuilt Outdoor Products© are not recommended.
- Never use this product for anything other than its intended purpose. This grill is not for commercial use.
- Always use this grill in accordance with all applicable local, state and federal fire codes.



WARNING



Combustion by-product produced when using this product contains chemicals known to the State of California to cause birth defects, other reproductive harm, or cancer.

The materials used in this product may contain lead a chemical known to the State of California to cause birth defects and other reproductive harm.

PARTS LIST

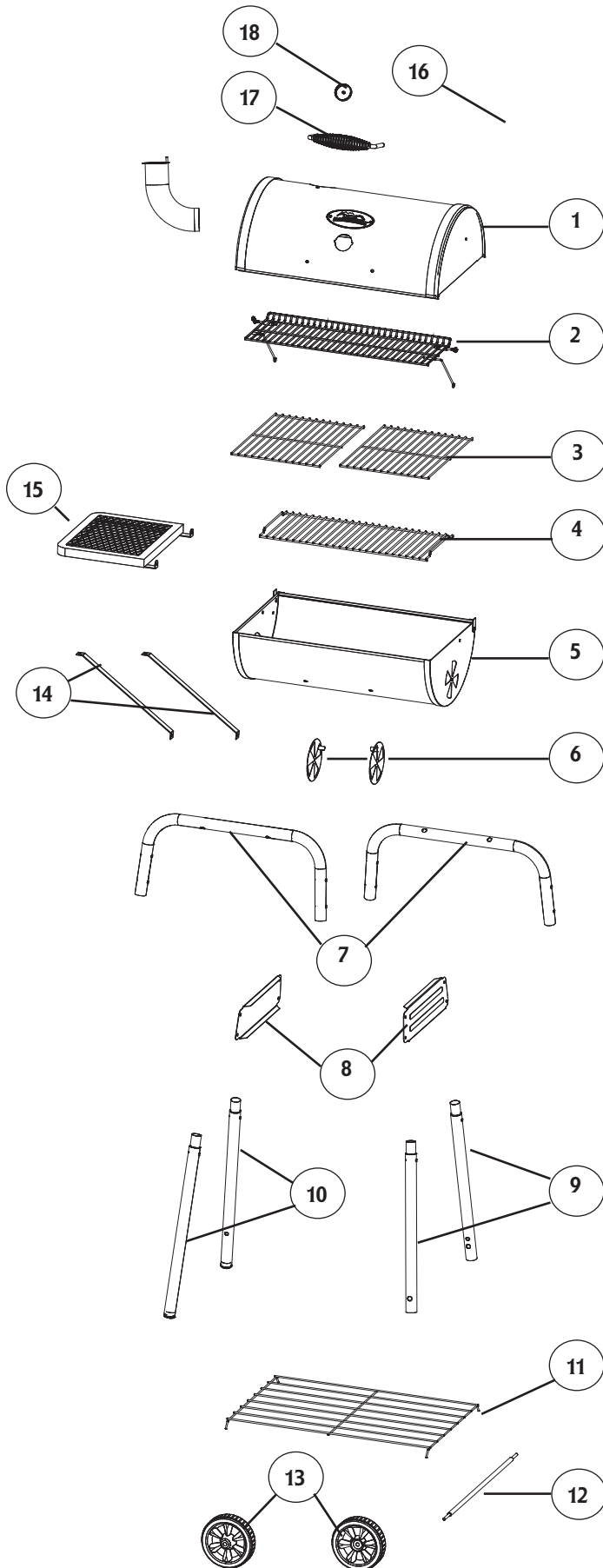

ITEM NO.	QUANTITY	DESCRIPTION
1	1	Grill Lid
2	1	Warming Rack
3	2	Cooking Grate
4	1	Charcoal Grate
5	1	Grill Body
6	2	Air Damper
7	2	Leg Connector
8	2	Leg Bracket
9	2	Short Axle Leg
10	2	Long Stationary Leg
11	1	Storage Shelf
12	1	Axle
13	2	Wheel
14	2	Side Shelf Bracket
15	1	Side Shelf
16	1	Smoke Stack
17	1	Lid Handle
18	1	Temperature Gauge (with Retainer Clip)

HARDWARE LIST

BLISTER PACK CONTENTS

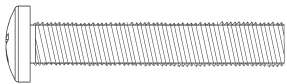

(A)
M6x45
Phillips Head Screw
qty-14

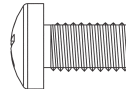

(D)
M6x12
Phillips Head Screw
qty-11

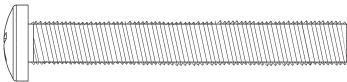

(B)
M6x70
Phillips Head Screw
qty-2

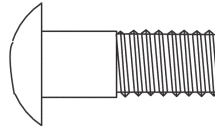

(E)
M6
Carriage Bolt
qty-2



(C)
M6
Hex Flange Nut
qty-20

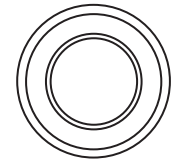
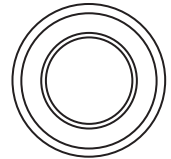

(J)
M6
Axle Cap
qty-2

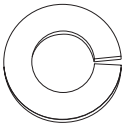

(F)
M6
Lock Washer
qty-2



(G)
M6
Flat Washer
qty-2



(H)
M6
Lock Nut
qty-6



(I)
Cotter Clip
qty-2

REPLACEMENT PARTS LIST



DO NOT RETURN TO RETAILER
For Assembly Assistance, Missing or Damaged Parts
Call: MASTERBUILT Customer Service at 1-800-489-1581

ITEM NO.	DESCRIPTION
9904100045	Lid Kit
9904100046	Grill Body Kit
9904100029	Smoke Stack Kit
9904100047	Side Shelf Kit
9904100048	Axle Leg Kit
9904100049	Stationary Leg Kit
9904100050	Leg Connector Tube Kit
9904100051	Leg Bracket Kit
9904100052	Side Shelf Support Kit
9904100053	Axle Kit
9904100054	Wheel Kit
9904100055	Warming Rack Kit
9904090029	Lid Handle Kit
990050018	Air Damper Kit
9904100056	Temperature Gauge Kit
9004100077	Lower Shelf (no Hardware)
9004100078	Axle Caps
9004100079	Cooking Grate
9004100080	Charcoal Grate
9904100068	Hardware Bag
9804100059	Instruction Manual - English

ASSEMBLY INSTRUCTIONS

Before assembly read instructions carefully.

This unit is heavy. Do not assemble without assistance.

Tools needed for assembly:

Adjustable Wrench
Phillips Head Screwdriver

Assemble grill on a clean, flat surface.

CAUTION: Use caution during the assembly process.

Some components are heavy.

STEP 1.

Pay close attention to when assembling grill legs. Right legs are shorter to accommodate wheels.

Insert right short leg (9) and left long stationary leg (10) into leg connector (7) as shown.

Repeat step 1 to assemble second set of legs.

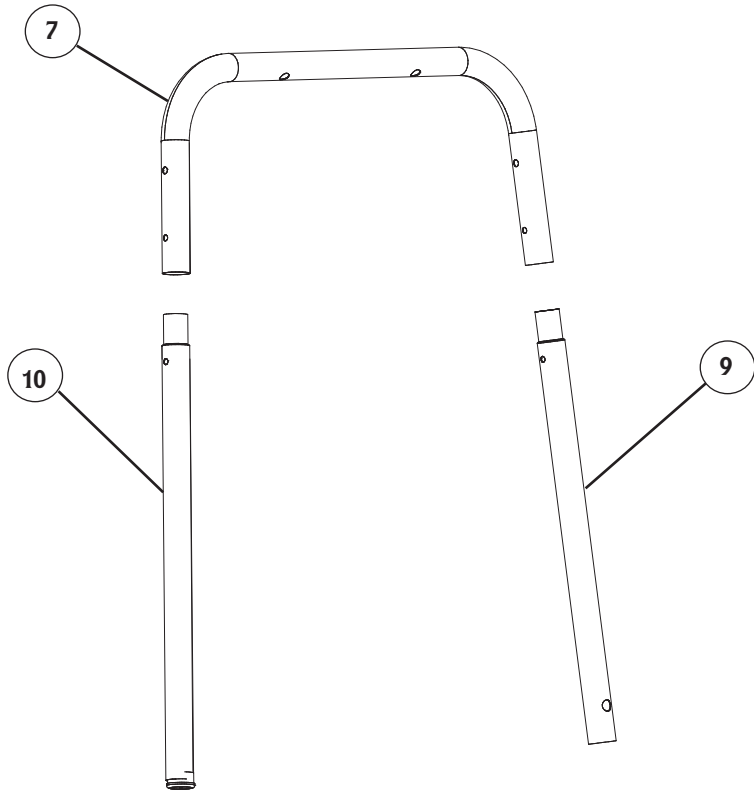

STEP 2.

Steps 2-3 require assistance. Get a helper!

Insert storage shelf (11) into holes of assembled grill legs as shown.

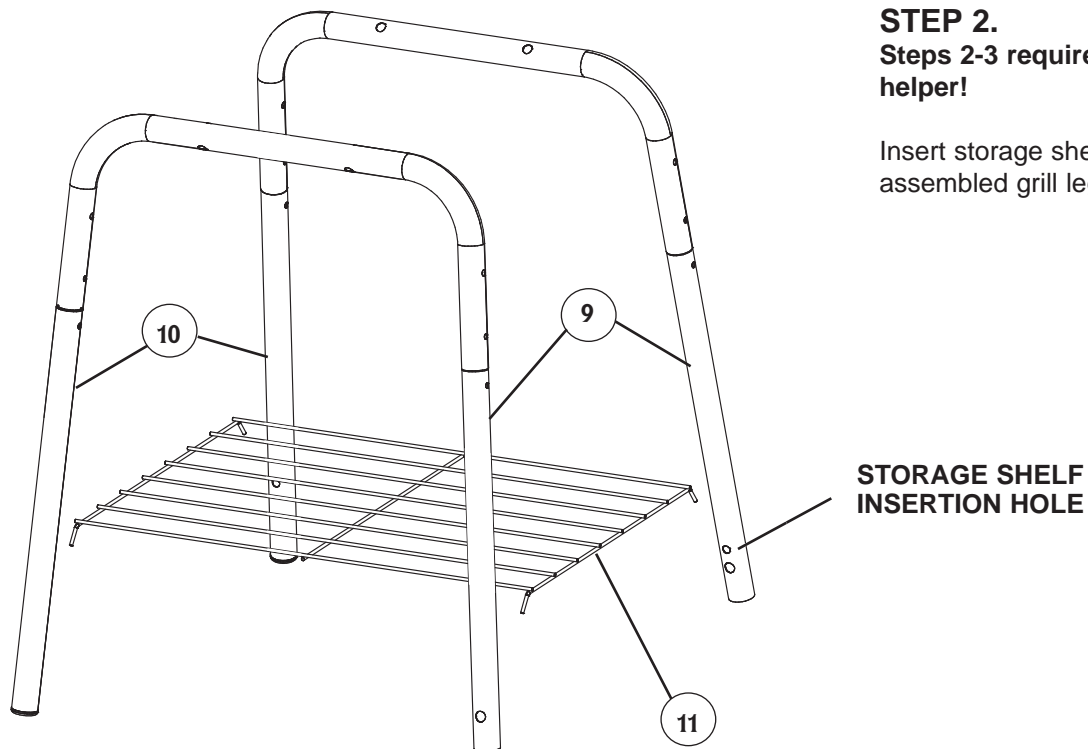

STEP 3.

Attach leg bracket (8) to right short legs (9) as shown using phillips head screws (A) and hex flange nuts (C).

Repeat step 3 on opposite side.

Do not fully tighten screws at this time.

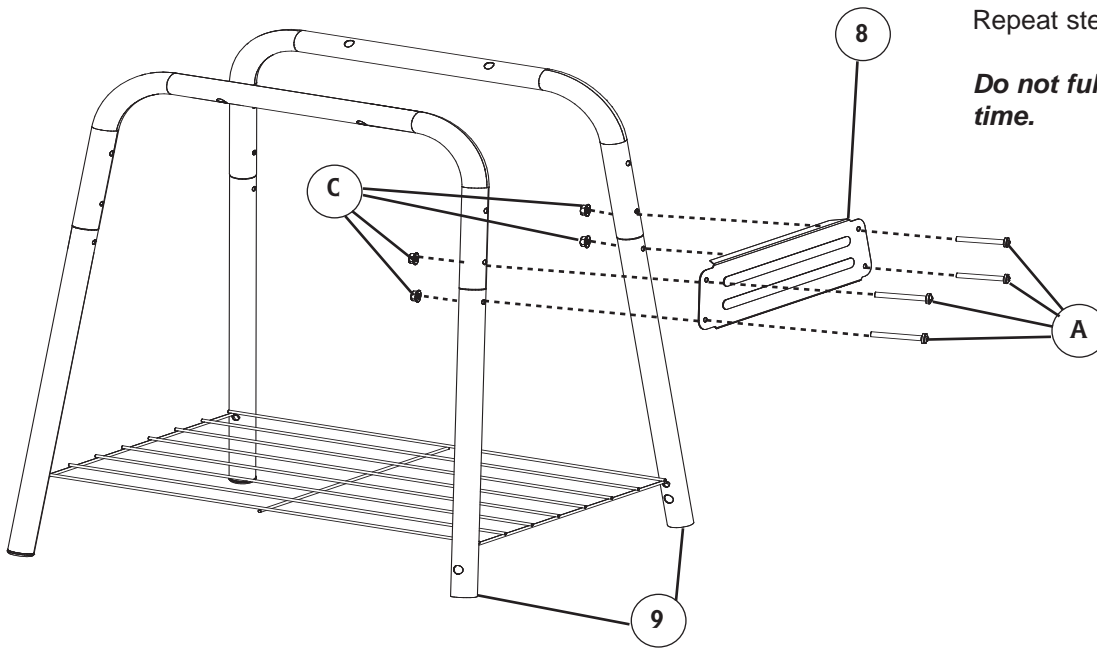

STEP 4.

Insert axle (12) through holes on short right legs (9). Slide wheel (13) onto axle and secure using cotter clip (I). Snap axle cap (J) onto end of wheel assembly as shown.

Repeat step on opposite side for remaining wheel.

Do not fully tighten screws at this time.

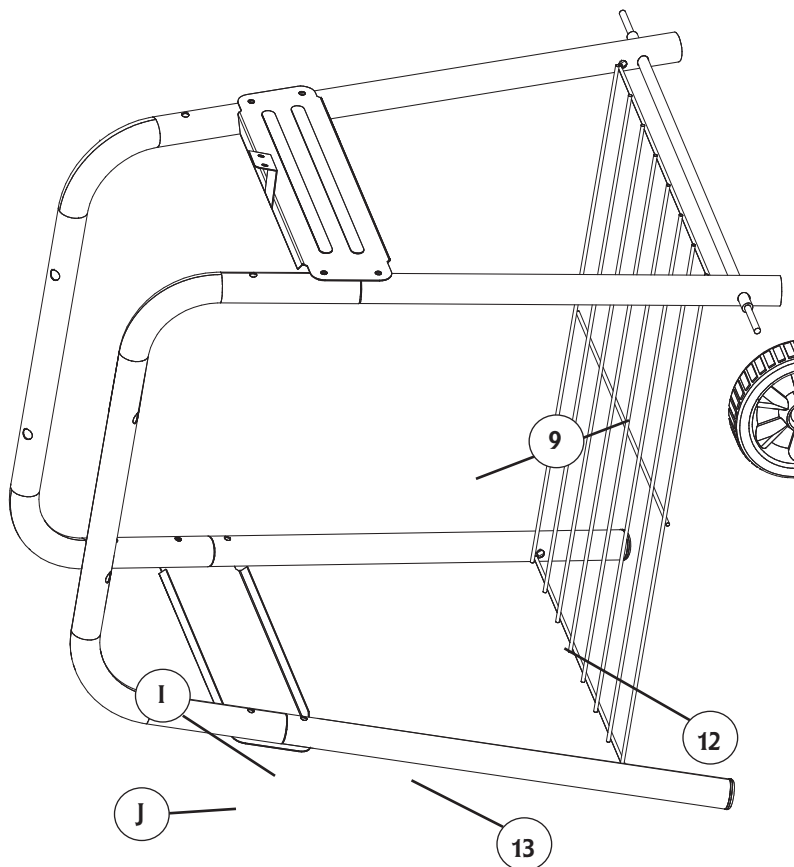

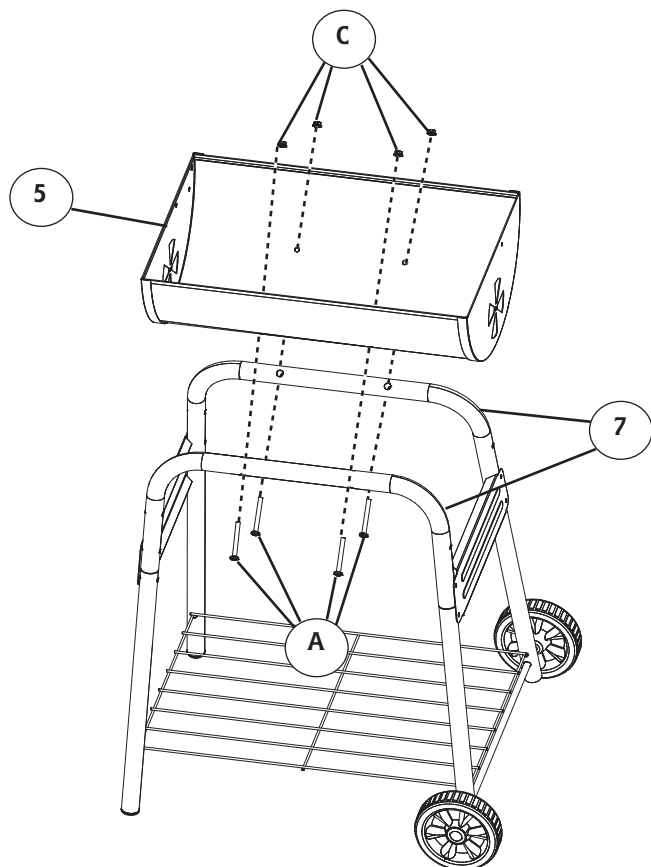

STEP 5.

Place grill body (5) onto assembled legs with holes for grill lid to the back.

Tightly secure grill body to leg connectors (7) using phillips head screws (A) and hex flange nuts (C).

Do not fully tighten screws at this time.

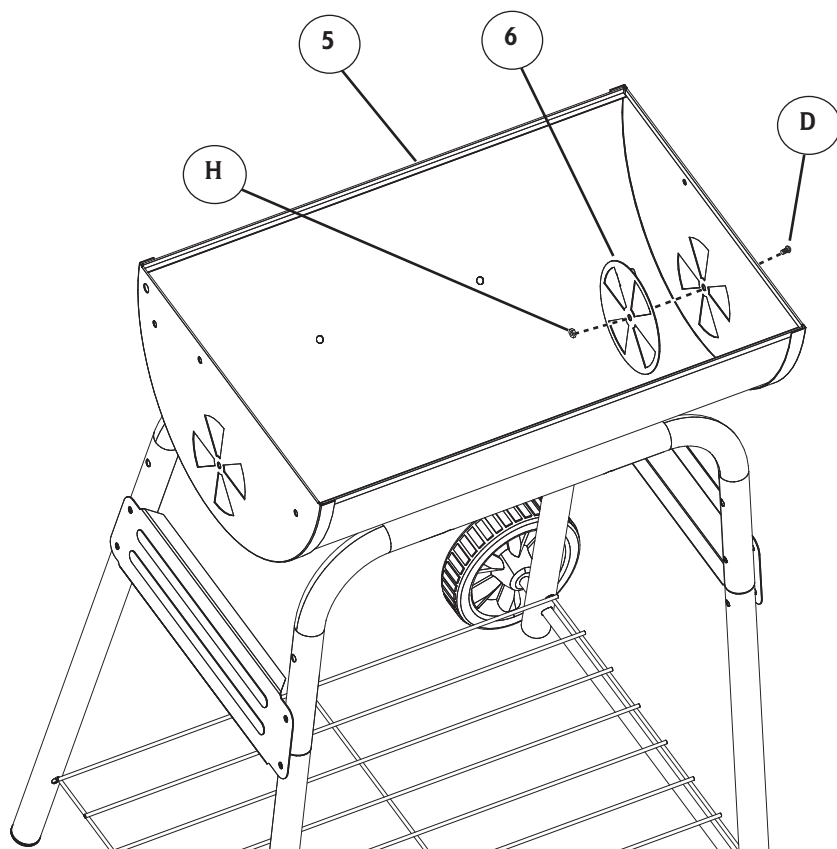

STEP 6.

Note: Do not over tighten. Air damper should move freely.

Attach air damper (6) to body (5) using phillips head screw (D) and lock nut (H) as shown.

Repeat step on opposite side.

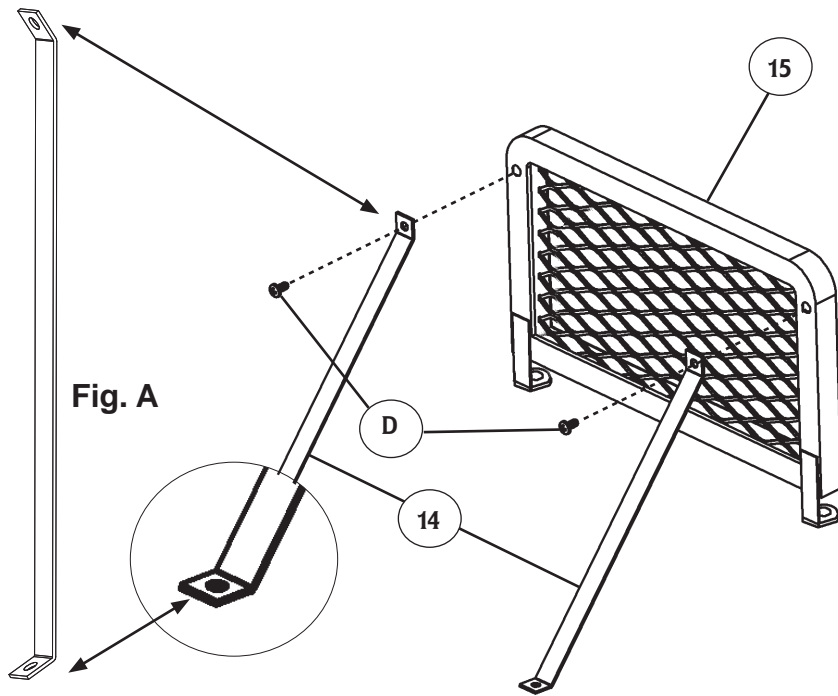

STEP 7.

Note: Position brackets so sharper angled end (Fig. A) is used to connect to leg connector.

Attach side shelf support brackets (14) to side shelf (15) using phillips head screws (D).

Do not fully tighten at this time.

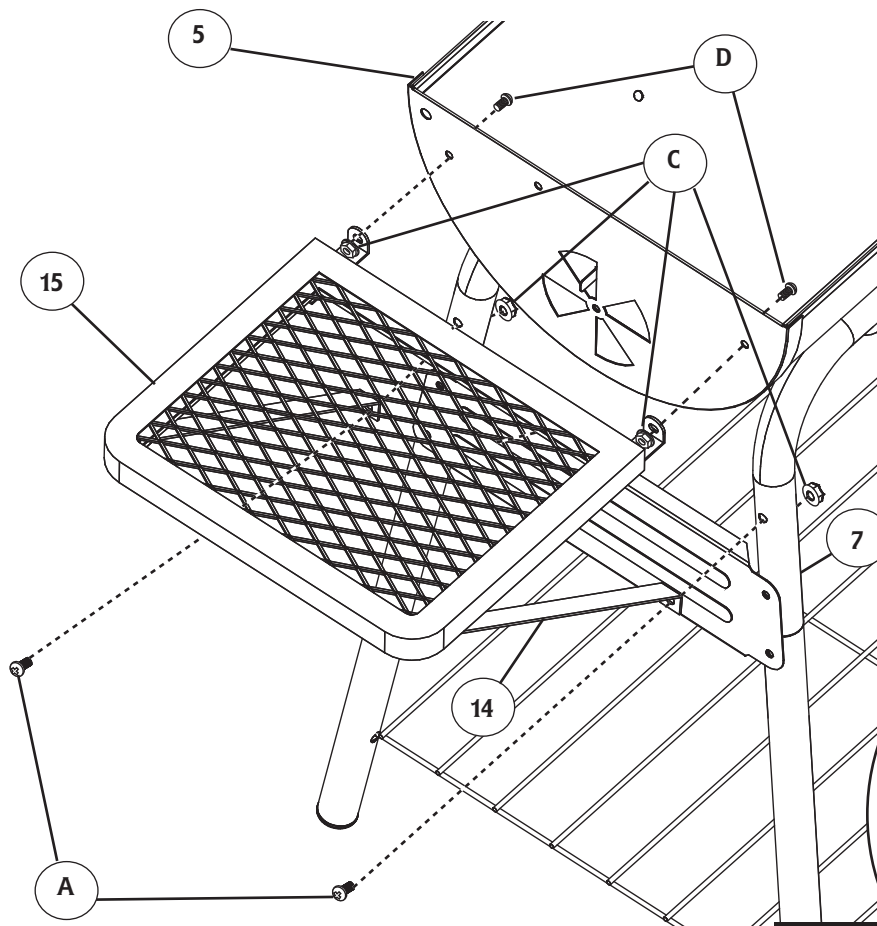

STEP 8.

Align holes on assembled side shelf (15) with holes on grill body (5) and leg connector (7) as shown.

Insert phillips head screw (D) through holes on body (5) into side shelf (15). Secure using hex flange nuts (C).

Attach shelf support brackets (14) to top holes in leg connector (7) as shown in illustration and Fig. A. using phillips head screws (A). Secure using hex flange nuts (C).

Do not fully tighten screws at this time.

Fig. A

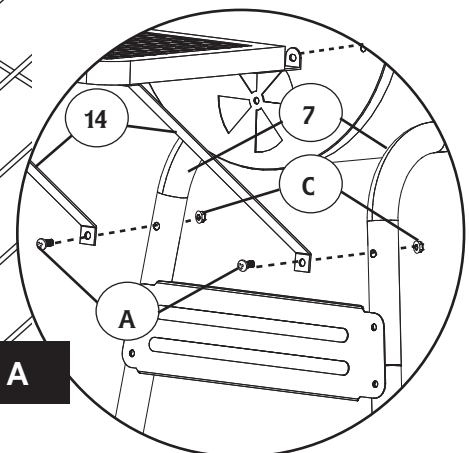

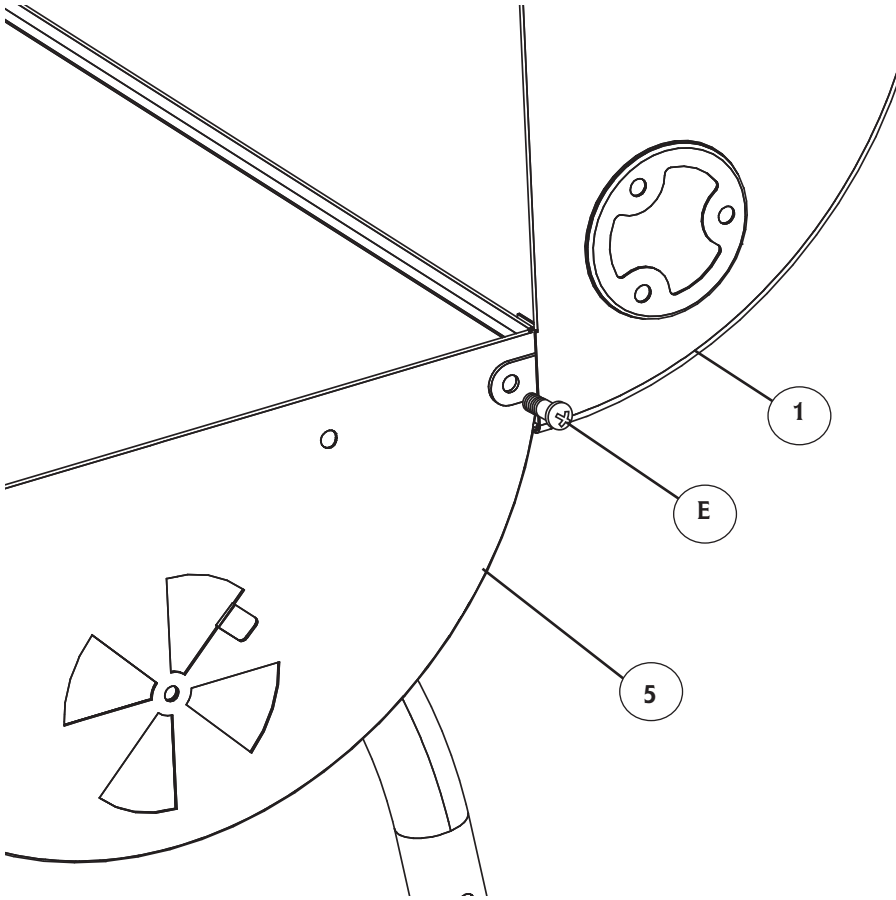

STEP 9.
Step 9 requires assistance.
Get a helper!

Align grill lid (1) with grill body (5) as shown. Secure grill lid (1) to grill body (5) using carriage bolt (E).

Repeat step on opposite end.

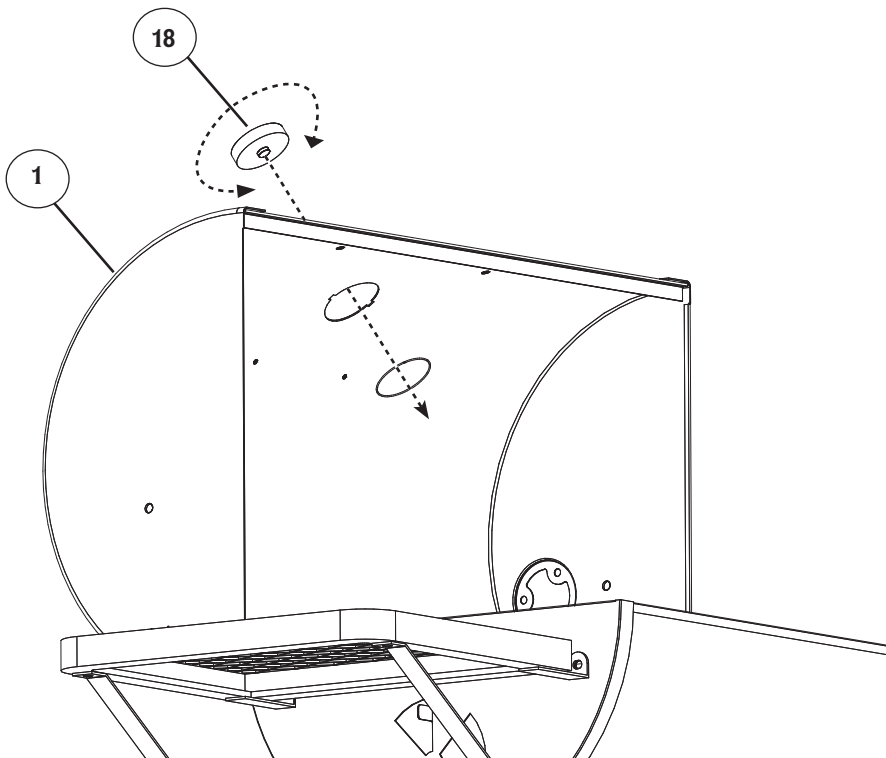

STEP 10.

Insert temperature gauge (18) through slotted hole in grill lid (1). Secure by turning temperature gauge (18) and lock into place with retainer ring.

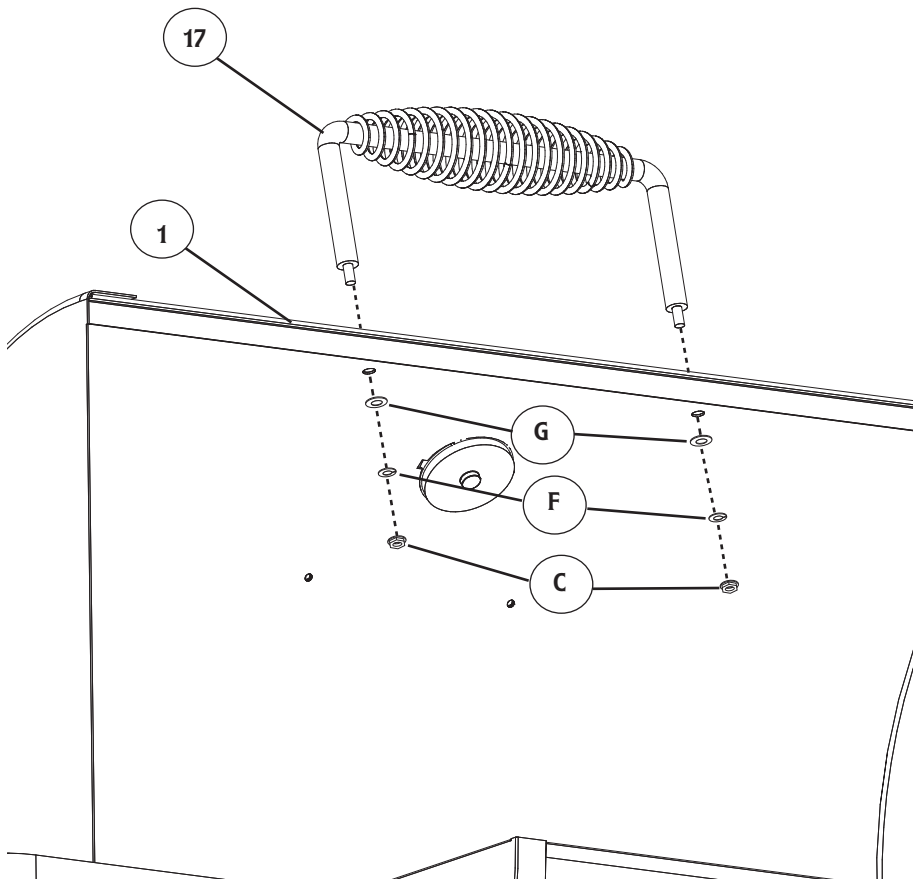

STEP 11.

Secure handle (17) to grill lid (1) using flat washer (G), lock washer (F) and hex flange nut (C).

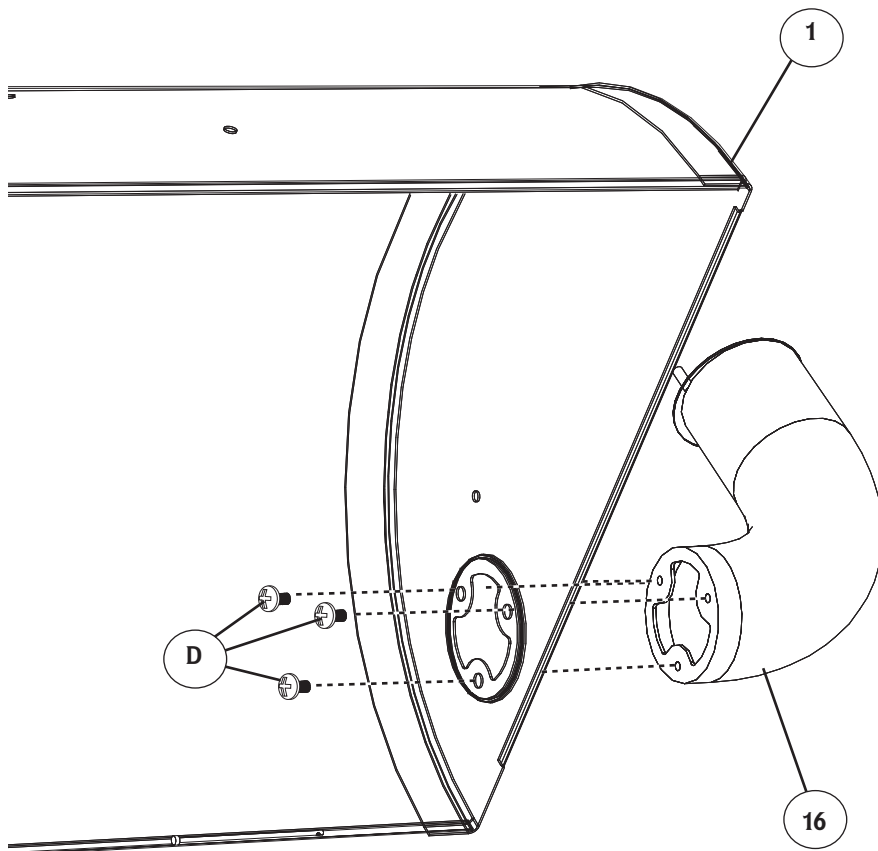

STEP 12.

Attach smoke stack (16) to right side of grill lid (1) and secure with phillips head screws (D) as shown.

STEP 13a.

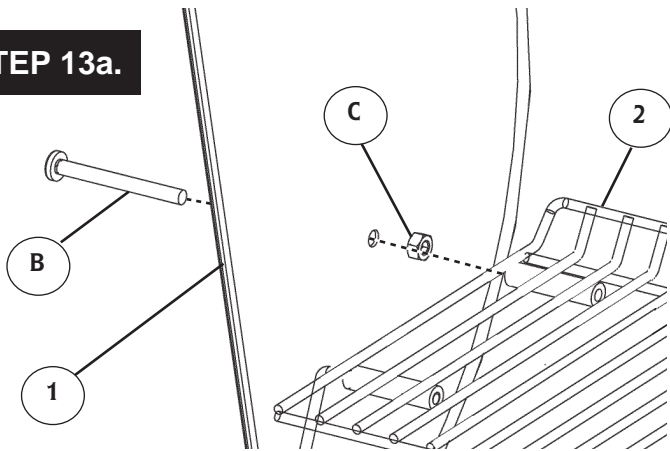

STEP 13a.

Insert warming rack support bolt (B) into hole on the left side of grill lid (1). Thread hex flange nut (C) onto bolt and tighten. Slide warming rack (2) eyelet onto end of support bolt.

Note: Warming rack should have some play and move freely.

STEP 13b.

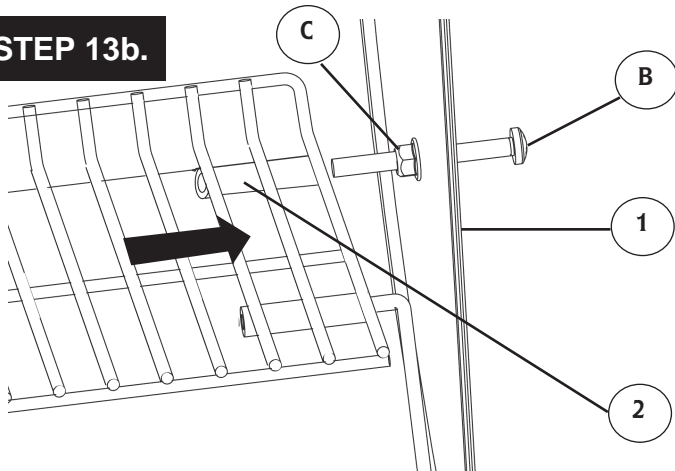

STEP 13b.

Slide warming rack to the far left to butt up against grill lid.

On right side of grill lid (1) hold hex flange nut (C) in place with hand and thread rack support bolt (B) through nut, guiding warming rack (2) onto support bolt as shown.

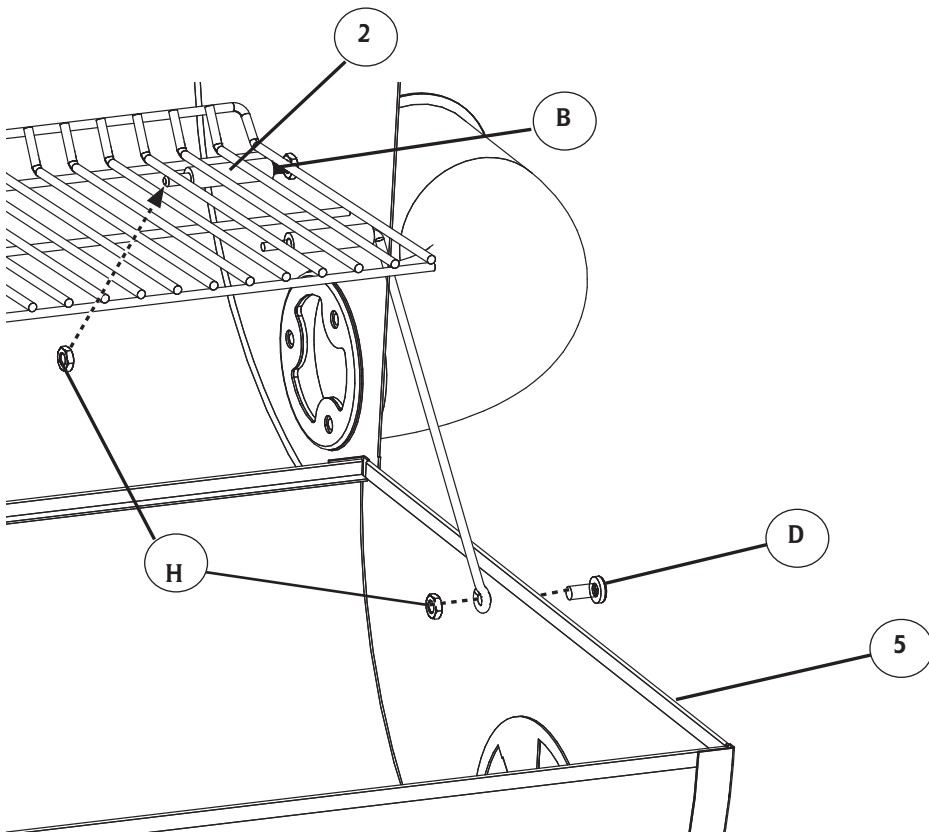

STEP 14.

Secure warming rack (2) to rack support bolt (B) using lock nut (H) as shown.

Note: Be sure not to overtighten lock nut (H), as rack is to move freely.

Secure warming rack support arm onto grill body (5) using phillips screw (D) and hex lock nut (H).

Repeat step on opposite side.

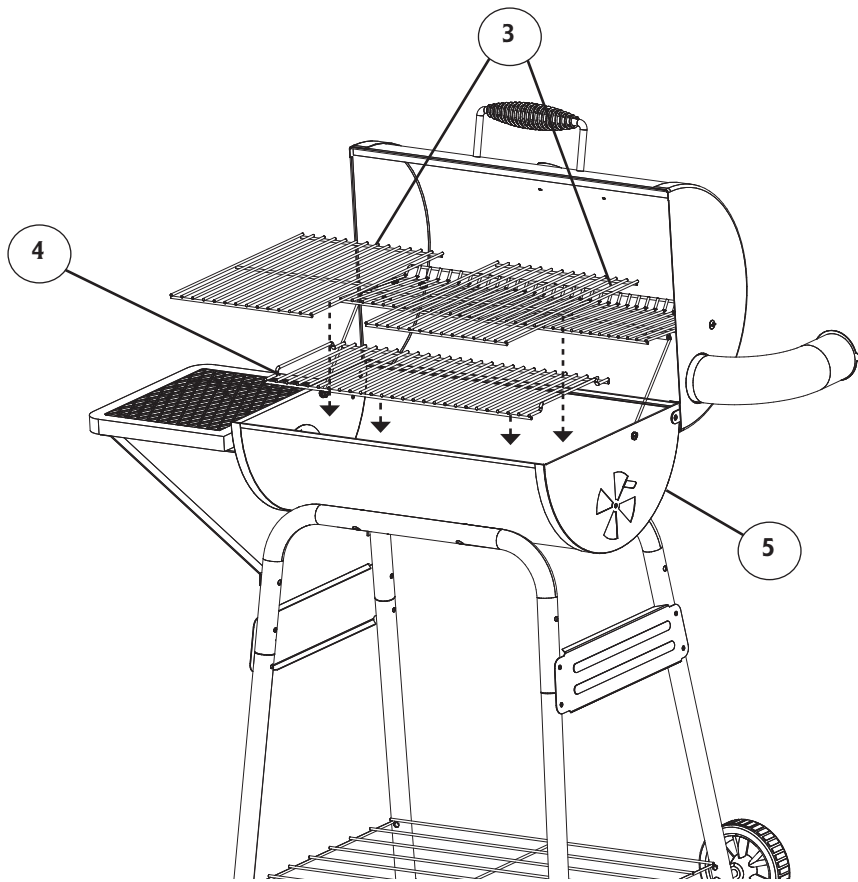

STEP 15.

Insert charcoal grate (4) inside grill and place cooking grates (3) on grill body (5) as shown .



GRILL IS READY FOR USE

FREQUENTLY ASKED QUESTIONS

Q: The paint finish inside my lid is peeling. What can I do?

You are seeing a deposit of grease and smoke that collects during normal use that resembles paint. These carbon deposits are non-toxic, but you may want to regularly remove the build-up. Remove buildup using a brass or stiff bristle brush before grilling. Future build-up can be avoided by simply wiping the grill lid while slightly warm with a mild soap-and-water solution.

Q: When can I put my meat on the grill?

Grill is ready for use when charcoal is ashed over and no visible flames are present.

Q: How do I regulate the heat on my grill?

Adjusting the dampers will increase and decrease airflow and heating.

SAFE STORAGE AND MAINTENANCE

- Inspect bolt, hex lock nut and hex flange nut tightness on a regular basis to ensure grill is in safe working condition.
- ALWAYS allow grill to cool completely before handling.
- ALWAYS empty charcoal pan after use only when ashes have completely cooled. This will help prolong charcoal pan life.
- Clean grill, including special surfaces such as cooking grates with mild cleaning agents. Wipe outside of grill with damp rag. DO NOT use oven cleaner.
- ALWAYS cover and store cold grill in a protected area.
- Indoor storage of grill is permissible only if the charcoal has burned to a complete ash AND is cold. Remember to remove cold ashes before storing.
- Grill is made of steel and may rust over time. If rusting occurs on outside surfaces, clean area with sand paper or steel wool, then cover with heat resistant paint.
- If rusting occurs on the inside surface of grill, clean area with sandpaper or steel wool, then coat with cooking oil.
- NEVER USE PAINT ON INSIDE SURFACES OF GRILL

GRILL OPERATION CAUTIONS

- Avoid bumping or impacting grill.
- Keep your hands, hair and face away from burning charcoal.
- This grill has an open flame. Be careful of loose hair and clothing during operation. They may catch fire.
- Use protective gloves when handling this grill or working with fire. Use protective gloves or long, sturdy fireplace tools when adding wood or charcoal.
- Do not allow anyone to conduct activities around this grill during or following its use until the unit has cooled. This grill is HOT during operation and remains HOT for a period of time following its use.
- Fatty foods like hamburgers can have excess grease that can cause flare ups. When cooking fatty foods, use caution when opening lid and during cooking to avoid being burned.
- Be careful when removing food from grill. All surfaces are HOT and may cause burns. Use protective gloves or long, sturdy cooking tools.
- Never use glass, plastic or ceramic cookware on this grill.
- The use of alcohol, prescription or non-prescription drugs may impair the user's ability to properly assemble or safely operate this grill.
- Grill lid and body are HOT while in use and during cooling process.
- Do not remove adjustable charcoal pan while ashes and charcoal are HOT.
- Air dampers are HOT while the grill is in use and during cooling; wear protective gloves when adjusting.
- Never overfill charcoal pan. This can cause serious injury as well as damage the unit.
- Only use charcoal lighting fluid, never use gasoline, alcohol or other highly volatile fluids to ignite the charcoal. These fluids can explode causing injury or death.

REMINDER: NEVER OPERATE THIS GRILL UNDER ANY OVERHEAD CONSTRUCTION. MAINTAIN A MINIMUM DISTANCE OF 10 FEET FROM OVERHEAD CONSTRUCTION, WALLS OR RAILS. SEE DIAGRAM BELOW.

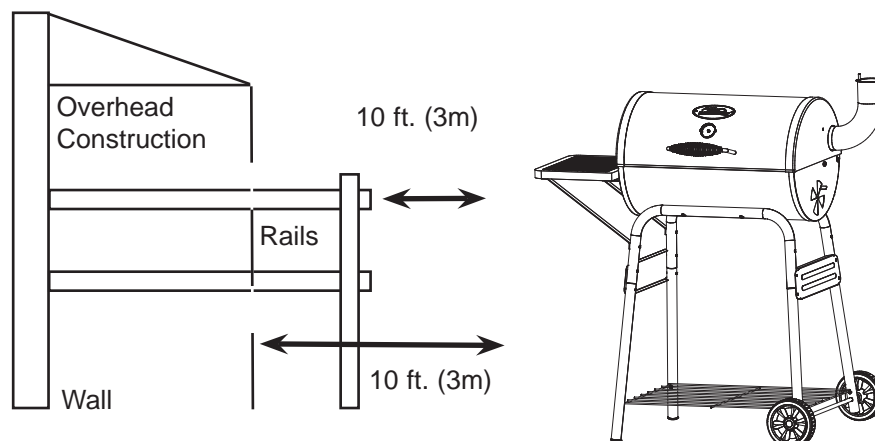

CHARCOAL LIGHTING INSTRUCTIONS

Read all instructions and warnings on charcoal bag and in manual before using.

1. Stack briquets in a pyramid.
 2. Add lighter fluid following directions on fluid container. Before lighting, place lighter fluid at least 25 ft. (7.5m) away from grill. Do not lean over grill when lighting charcoal. Light charcoal. LEAVE GRILL UNCOVERED.
 3. In about 15 minutes, flames will die out and briquets will begin to ash over. Once the briquets are completely ashed over, spread briquets in a single layer and begin cooking.
- NEVER USE GASOLINE TO LIGHT CHARCOAL.
 - OVERFILLING CHARCOAL PAN CAN CAUSE SERIOUS INJURY AND DAMAGE THE UNIT.
 - NEVER ADD ADDITIONAL LIGHTER FLUID ONCE CHARCOAL HAS IGNITED.
 - HOT COALS SHOULD NOT BE LEFT UNATTENDED.
 - GRILL IS HOT. USE PROTECTIVE GLOVES AND LONG, STURDY COOKING UTENSILS.

TO ENSURE THAT IT IS SAFE TO EAT, FOOD MUST BE COOKED TO THE MINIMUM INTERNAL TEMPERATURES LISTED IN THE TABLE BELOW.

USDA* Safe Minimum Internal Temperatures	
Fish	145°F (63°C)
Pork	160°F (71°C)
Egg Dishes	160°F (71°C)
Steaks and Roasts of Beef, Veal or Lamb	145°F (63°C)
Ground Beef, Veal or Lamb	160°F (71°C)
Whole Poultry (Turkey, Chicken, Duck, etc.)	165°F (74°C)
Ground or Pieces Poultry (Chicken Breast, etc.)	165°F (74°C)

*** United States Department of Agriculture**

RECIPES

HONEY GRILLED SALMON

3/4 cup honey
1 tsp ground black pepper
1/3 cup soy sauce
1/2 tsp cayenne pepper
1/4 cup dark brown sugar, packed
1/2 tsp paprika
1/4 cup pineapple juice
1/4 tsp garlic powder
Juice of 1 lemon (about 2 tbsp)
4 8oz salmon fillets (without skin)
2 tbsp white vinegar
2 tsps olive oil
vegetable oil

Make the sauce by combining all ingredients in a medium saucepan over medium/low heat. Stir occasionally until sauce begins to boil, then simmer uncovered for 15 minutes or until syrupy. Watch the sauce closely to be sure it doesn't bubble over. Preheat barbecue grill to medium heat. Rub each salmon fillet with vegetable oil, then sprinkle salt and pepper. Grill the salmon for 4 to 7 minutes per side or until done. Serve salmon with a small cup of the honey pepper sauce on the side.

CLASSIC BURGERS

1 1/2 lb ground beef chuck (80% lean)
1 tsp salt
1 tsp Worcestershire sauce
3/4 tsp freshly ground pepper
4 slices sharp cheddar cheese
4 large sesame hamburger buns, split
1/2 thousand island BBQ dressing (recipe follows)
4 thick slices large tomato
4 thick slices large sweet onion
4 leaves lettuce

In medium bowl, gently mix together beef, salt, Worcestershire sauce and pepper. Shape into 4 (4 inch thick) patties 3/4 inch thick. Heat grill. Place burgers on grill 4 to 6 inches from medium coals; cover grill. Grill 7 to 8 minutes or until thoroughly cooked and no longer pink in center, turning once. Top each burger with 1 slice cheese; grill 1 minute or until cheese has melted. Place buns on grill; grill 30 to 60 seconds or until lightly toasted. Spread each bun with 2 tbsp of the dressing. Top burgers with tomato, onion and lettuce.

Thousand Island BBQ Dressing
1 cup mayonnaise
1/4 cup chili sauce
2 tablespoon smoky barbeque sauce
1 tablespoon sweet pickle relish
1 tsp Worcestershire sauce

In small bowl, stir together all ingredients until well blended.

HOMEMADE PORK SAUSAGE LINKS

3 tbsp finely snipped fresh basil
1 tsp sugar
1 tsp fennel seeds
1 tsp crushed red pepper
3/4 tsp salt
1/2 tsp black pepper
1 clove garlic, minced
1 1/2 lbs ground pork
4 frankfurter buns, split and toasted
1/4 cup Bacon and Brown Sugar Mustard

In a bowl, combine basil, sugar, fennel seeds, red pepper, salt, black pepper, and garlic. Add ground pork; mix well. Divide pork mixture into four equal portions. Shape each portion around a flat-sided metal skewer into a 6 inch long link. Grill links on the rack of an uncovered grill directly over medium coals for 14 to 18 minutes or until done (160 degrees), turning once halfway through grilling.

Bacon and Brown Sugar Mustard

In small bowl stir together 3/4 cup yellow mustard; 3 slices of bacon, crisp-cooked, drained, and finely crumbled; and 4 tsps packed brown sugar. Cover and chill for 8 hours to 2 days. Makes 1 cup.

CHERRY CHICKEN

1 cup cherry preserves
1 tbs. margarine or butter
1/2 tsp. finely shredded lemon peel
2 tbs. lemon juice
1/2 tsp. ground cinnamon
1/4 tsp. ground allspice
1/8 tsp. salt
Dash of ground cloves
2 to 2 1/2 lbs chicken pieces

In a small sauce pan combine cherry preserves, margarine or butter, lemon peel, lemon juice, cinnamon, allspice, salt, and cloves. Cook and stir until all combined. Remove skin from chicken (if desired red). Rinse chicken; pat dry. Preheat grill. Adjust heat for direct cooking. Place chicken, bone side up on grill rack over medium heat. Cover and grill for 30 to 45 minutes or until tender and no longer pink. Turn chicken halfway through cooking. Brush with sauce frequently the last 10 minutes of grilling.

APPROXIMATE GRILLING TIMES

BEEF	SIZE	GRILLING TIME	INTERNAL TEMP
Steaks	¾" (2cm) thick	3 to 4 min. /side	med rare 145°F (62°C)
		4 to 5 min. /side	med 160°F (71°C)
Kabobs	1" (2.5cm) cubes	3 to 4 min. /side	145°-160°F (62-71°C)
Hamburger patties	½" (12mm) thick	3 to 4 min. /side	med 160°F (71°C))
Roast, rolled rump	4-6 lbs. (1.8-2.7kg)	18 to 22 min /lb.	145°-160°F (62-71°C)
Sirloin tip	3 ½-4 lbs. (1.5-1.8kg)	20 to 25 min. /lb.	145°-160°F (62-71°C)
Ribs, back	cut in 1-rib portions	10 min. /side	med 160°F (71°C)
	half, 2-3 lbs. (0.9-1.3kg)	10 to 12 min. /side	med rare 145°F (62°C)
Tenderloin	whole, 4-6 lbs. (1.8-2.7kg)	12 to 15 min. /side	med 160°F (71°C)
PORK	SIZE	GRILLING TIME	INTERNAL TEMP
Chops, bone-in	¾" (2cm) thick	3 to 4 min. /side	med 160°F (71°C)
Chops, bone-out	1 ½" (4cm) thick	7 to 8 min. /side	med 160°F (71°C)
Tenderloin	½-1 ½ lbs. (0.2-0.6kg)	15 to 25 min. total	med 160°F (71°C)
Ribs (indirect heat)	2-4 lbs. (0.9-1.8kg)	1 ½ to 2 hrs.	med 160°F (71°C)
VENISON	SIZE	GRILLING TIME	INTERNAL TEMP
Roast, saddle or leg	6-7 lbs. (2.7-3.1kg)	25 to 30 min. /lb.	145°-160°F (62-71°C)
Steaks	¾" (2cm) thick	6 to 7 min. /side	med 160°F (71°C)
CHICKEN	SIZE	GRILLING TIME	INTERNAL TEMP
Broiler fryer (indirect heat)	3-4 lbs. (1.3-1.8kg)	60 to 75 min.	in thigh 180°F (82°C)
Cornish hens	18-24 oz. (510-680g)	45 to 55 min.	in thigh 180°F (82°C)
Breast halves, bone-in	6-8 oz. (170-226g) each	10 to 15 min. /side	170°F (77°C)
Breast halves, boneless	4 oz. (113g) each	6 to 8 min. /side	170°F (77°C)
Legs or thighs	4-8 oz. (113-226g)	10 to 15 min. /side	180°F (82°C)
Drumsticks	4 oz. (113g)	8 to 12 min. /side	180°F (82°C)
Wings	2-3 oz. (56-85g)	8 to 12 min. /side	180°F (82°C)

- When outside temperature is cooler than 65°F (18°C) and/or altitude is above 3,500 ft. (1067m), additional cooking time may be required. To insure that meat is completely cooked use a meat thermometer to test internal temperature.

- Lifting grill lid during cooking process may extend cooking time due to heat loss.

LIMITED WARRANTY INFORMATION

Masterbuilt warrants its products to be free from defects in material and workmanship under proper assembly, normal use and recommended care for 90 days from the date of original retail purchase.

Masterbuilt warranty does not cover paint finish as it may burn off during normal use.

Masterbuilt warranty does not cover rust of the unit.

Masterbuilt requires reasonable proof of purchase for warranty claims and suggests that you keep your receipt. Upon the expiration of such warranty, all such liability shall terminate.

Within the stated warranty period, Masterbuilt, at its discretion, shall repair or replace defective components free of charge with owner being responsible for shipping. Should Masterbuilt require return of component(s) in question for inspection Masterbuilt will be responsible for shipping charges to return requested item.

This warranty excludes property damage sustained due to misuse, abuse, accident, damage arising out of transportation, or damage incurred by commercial use of this product.

This expressed warranty is the sole warranty given by Masterbuilt and is in lieu of all other warranties, expressed or implied including implied warranty, merchantability, or fitness for a particular purpose.

Neither Masterbuilt nor the retail establishment selling this product, has authority to make any warranties or to promise remedies in addition to or inconsistent with those stated above.

Masterbuilt's maximum liability, in any event, shall not exceed the purchase price of the product paid by the original consumer/ purchaser. Some states do not allow the exclusion or limitation of incidental or consequential damages. In such a case, the above limitations or exclusions may not be applicable.

California residents only: Notwithstanding this limitation of warranty, the following specific restrictions apply; if service, repair, or replacement of the product is not commercially practical, the retailer selling the product or Masterbuilt will refund the purchase price paid for the product, less the amount directly attributable to use by the original buyer prior to the discovery of the nonconformity. Owner may take the product to the retail establishment selling this product in order to obtain performance under warranty.

This expressed warranty gives you specific legal rights, and you may also have other rights which vary from state to state.

Go Online www.masterbuilt.com

or complete and return to

Attn: Warranty Registration

Masterbuilt Mfg. Inc.

1 Masterbuilt Court - Columbus, GA 31907

Name: _____

Address: _____

City, State/Province, Postal Code: _____

Phone Number: _____ E-Mail Address: _____

Model Number: _____ Serial Number: _____

Purchase Date: _____ Place of Purchase: _____



**Masterbuilt Manufacturing, Inc.
1 Masterbuilt Court
Columbus, Georgia 31907
Customer Service 1-800-489-1581**