



**Masterbuilt Manufacturing, Inc**  
A Georgia Company  
1 Masterbuilt Court  
Columbus, Georgia 31907  
Customer Service 1-800-489-1581



**ASSEMBLY, CARE & USE MANUAL**  
**WARNING & SAFETY INFORMATION**  
THIS PRODUCT IS FOR OUTDOOR USE ONLY

**ELECTRIC VERANDA**  
**MODEL 20150309**

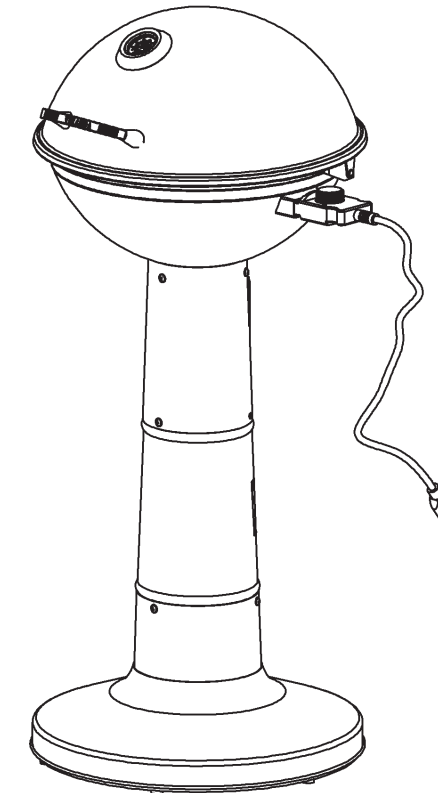

Manual Code: 15080022 090205

Approximate assembly time: 20 minutes.  
Tools required for assembly: Phillips Head Screwdriver.



**WARNING**



**This manual contains important information  
necessary for the proper and safe use of this unit.**

**Read and follow all warnings and instructions before using  
grill and during use.**

**Keep this manual for future reference.**

**Use only outdoors where it is well ventilated.**

**Failure to follow these warnings and instructions properly could result in fire or explosion, which could  
cause property damage, personal injury, or death.**



## GENERAL WARNINGS AND SAFETY INFORMATION



- Cannot be operated for more than 3 hours.
- Use GFI protected electrical outlet to reduce the risk of electrical shock.
- Never burn charcoal or wood in this unit.
- Place unit on a level surface to prevent possible tipping.
- To avoid injury disconnect electric cord from outlet before cleaning and servicing.
- To reduce risk of electric shock, keep extension cord dry and off the ground.
- Minimum distance from side and back of appliance to walls or railing is 24 inches.
- Do not use unit near heat sensitive or combustible structures such as vinyl or wood siding.
- Store appliance indoors when not in use, out of reach of children.
- Use only electric controller and element supplied with unit. These parts must be replaced by the manufacturer of unit.
- If a longer extension cord is used, the marked rating should be at least as great as electrical rating of appliance.
- Extension cord should be a grounding-type 3- wire cord.
- Outdoor extension cords should be used with outdoor use products and marked with suffix “W-A” and with statement “Suitable for Outdoor Appliances.”
- Do not clean this appliance with a water spray or the like.
- Keep hands, hair and face away from the element. Be careful of loose hair and clothing during operation, they could catch fire.
- Never use glassware, plastic or ceramic cookware on this grill.
- Preheating grill is not necessary. If preheating is desired, open lid with caution.



## CAUTION



- Fatty foods (hamburgers, etc.) can have excess grease and cause flare ups. When cooking fatty foods, use a low setting with lid open.
- Clean internal base pan before each use. This will cut down on build-up and flare ups.



## DANGER



- Do not expose electric grill to rain. Do not use around water or operate on wet surfaces. This could cause an electric shock leading to injury or death.

## LIMITED WARRANTY INFORMATION

Masterbuilt warrants its products to be free from defects in material and workmanship under proper assembly, normal use and recommended care for 90 days from the date of original retail purchase.

Masterbuilt warranty does not cover paint finish as it may burn off during normal use.

Masterbuilt warranty does not cover rust of the unit.

Masterbuilt requires reasonable proof of purchase for warranty claims and suggests that you keep your receipt. Upon the expiration of such warranty, all such liability shall terminate.

Within the stated warranty period, Masterbuilt, at its discretion, shall repair or replace defective components free of charge with owner being responsible for shipping. Should Masterbuilt require return of component(s) in question for inspection Masterbuilt will be responsible for shipping charges to return requested item.

This warranty excludes property damage sustained due to misuse, abuse, accident, damage arising out of transportation, or damage incurred by commercial use of this product.

*This expressed warranty is the sole warranty given by Masterbuilt and is in lieu of all other warranties, expressed or implied including implied warranty, merchantability, or fitness for a particular purpose.*

Neither Masterbuilt nor the retail establishment selling this product, has authority to make any warranties or to promise remedies in addition to or inconsistent with those stated above.

Masterbuilt's maximum liability, in any event, shall not exceed the purchase price of the product paid by the original consumer/ purchaser. Some states do not allow the exclusion or limitation of incidental or consequential damages. In such a case, the above limitations or exclusions may not be applicable.

**California residents only:** Notwithstanding this limitation of warranty, the following specific restrictions apply; if service, repair, or replacement of the product is not commercially practical, the retailer selling the product or Masterbuilt will refund the purchase price paid for the product, less the amount directly attributable to use by the original buyer prior to the discovery of the nonconformity. Owner may take the product to the retail establishment selling this product in order to obtain performance under warranty.

This expressed warranty gives you specific legal rights, and you may also have other rights which vary from state to state.

### COMPLETE & RETURN TO

**ATTN: WARRANTY REGISTRATION**

**Masterbuilt Manufacturing, Inc.**

1 Masterbuilt Court - Columbus, GA 31907

Name: \_\_\_\_\_

Address: \_\_\_\_\_

City: \_\_\_\_\_

State/Province: \_\_\_\_\_ Postal Code: \_\_\_\_\_

Phone Number: \_\_\_\_\_ E-Mail Address: \_\_\_\_\_

Model Number: \_\_\_\_\_ Serial Number: \_\_\_\_\_

Purchase Date: \_\_\_\_\_ Place of Purchase: \_\_\_\_\_

## APPROXIMATE GRILLING TIMES

BEEF	SIZE	GRILLING TIME	INTERNAL TEMP
Steaks	¾" (2cm) thick	3 to 4 min. /side	med rare 145°F (62°C)
		4 to 5 min. /side	med 160°F (71°C)
Kabobs	1" (2.5cm) cubes	3 to 4 min. /side	145°-160°F (62-71°C)
Hamburger patties	½" (12mm) thick	3 to 4 min. /side	med 160°F (71°C)
Roast, rolled rump	4-6 lbs. (1.8-2.7kg)	18 to 22 min. /lb.	145°-160°F (62-71°C)
Sirloin tip	3 ½-4 lbs. (1.5-1.8kg)	20 to 25 min. /lb.	145°-160°F (62-71°C)
Ribs, back	cut in 1-rib portions	10 min. /side	med 160°F (71°C)
	half, 2-3 lbs. (0.9-1.3kg)	10 to 12 min. /side	med rare 145°F (62°C)
Tenderloin	whole, 4-6 lbs. (1.8-2.7kg)	12 to 15 min. /side	med 160°F (71°C)
PORK	SIZE	GRILLING TIME	INTERNAL TEMP
Chops, bone-in	¾" (2cm) thick	3 to 4 min. /side	med 160°F (71°C)
Chops, bone-out	1 ½" (4cm) thick	7 to 8 min. /side	med 160°F (71°C)
Tenderloin	½-1 ½ lbs. (0.2-0.6kg)	15 to 25 min. total	med 160°F (71°C)
Ribs (indirect heat)	2-4 lbs. (0.9-1.8kg)	1 ½ to 2 hrs.	med 160°F (71°C)
VENISON	SIZE	GRILLING TIME	INTERNAL TEMP
Roast, saddle or leg	6-7 lbs. (2.7-3.1kg)	25 to 30 min. /lb.	145°-160°F (62-71°C)
Steaks	¾" (2cm) thick	6 to 7 min. /side	med 160°F (71°C)
CHICKEN	SIZE	GRILLING TIME	INTERNAL TEMP
Broiler fryer (indirect heat)	3-4 lbs. (1.3-1.8kg)	60 to 75 min.	in thigh 180°F (82°C)
Cornish hens	18-24 oz. (510-680g)	45 to 55 min.	in thigh 180°F (82°C)
Breast halves, bone-in	6-8 oz. ( 170-226g) each	10 to 15 min. /side	170°F (77°C)
Breast halves, boneless	4 oz. (113g) each	6 to 8 min. /side	170°F (77°C)
Legs or thighs	4-8 oz. (113-226g)	10 to 15 min. /side	180°F (82°C)
Drumsticks	4 oz. (113g)	8 to 12 min. /side	180°F (82°C)
Wings	2-3 oz. (56-85g)	8 to 12 min. /side	180°F (82°C)

- When outside temperature is cooler than 65°F (18°C) and/or altitude is above 3,500 ft. (1067m), additional cooking time may be required. To insure that meat is completely cooked use a meat thermometer to test internal temperature.
- Lifting grill lid during cooking process may extend cooking time due to heat loss.



## GENERAL WARNINGS AND SAFETY INFORMATION



- For outdoor use only. Do not operate in an enclosed area.
- Unit **MUST** be on the ground. Do not place on tables or counters.
- Do not plug in electric grill until fully assembled and ready for use.
- Use only approved grounded GFI electrical outlet.
- Do not use during an electrical storm.
- To protect against electrical shock do not immerse cord, plug or control panel in water or other liquid.
- Do not operate any appliance with a damaged cord or plug or after appliance malfunctions or has been damaged in any manner. Contact Masterbuilt Customer Service for assistance at 1-800-489-1581.
- Keep a fire extinguisher accessible at all times while operating electric grill.
- Do not let cord touch hot surfaces.
- Do not place on or near a hot gas or electric burner, or in a heated oven.
- Never leave electric grill unattended while in use.
- Keep children and pets away from electric grill at all times. Do not allow children to use electric grill.
- Close supervision is necessary should children or pets be in area where electric grill is being used.
- Fuel, such as charcoal briquettes, are not to be used in electric grill.



## WARNING



Combustion by-product produced when using this product contains chemicals known to the State of California to cause birth defects, other reproductive harm, or cancer.

The materials used in this product may contain lead a chemical known to the State of California to cause birth defects and other reproductive harm.

**GENERAL WARNINGS AND SAFETY INFORMATION continued**

- Never use electric grill as a heater.
- Use electric grill only on a level, stable surface to prevent tipping.
- Electric grill is HOT while in use and will remain HOT for a period of time afterwards. Use caution.
- Do not allow anyone to conduct activities around electric grill during or following its use until the unit has cooled.
- The use of alcohol, prescription or non-prescription drugs may impair the user's ability to properly assemble or safely operate electric grill.
- Avoid bumping or impacting electric grill.
- Never move electric grill when in use. Allow electric grill to cool completely before moving or storing.
- Be careful when removing food from electric grill. All surfaces are HOT and may cause burns. Use protective gloves or long, sturdy cooking tools.
- Be sure drip tray is clean before each use.
- To disconnect, turn control panel "OFF" then remove plug from outlet.
- Unplug from outlet when not in use and before cleaning. Allow unit to cool completely before putting on or taking off parts.
- Accessory attachments not supplied by Masterbuilt Manufacturing, Inc. are not recommended and may cause injury.
- Never use electric grill for anything other than its intended purpose. This unit is not for commercial use.
- Always use electric grill in accordance with all applicable local, state and federal fire codes.

**SAVE THESE INSTRUCTIONS**

**WARNING**

To ensure that it is safe to eat, food must be cooked to the minimum internal temperatures listed in the table below.

USDA* Safe Minimum Internal Temperatures	
Fish	145° F
Pork	160° F
Egg Dishes	160° F
Steaks and Roasts of Beef, Veal or Lamb	145° F
Ground Beef, Veal or Lamb	160° F
Whole Poultry (Turkey, Chicken, Duck, etc.)	165° F
Ground or Pieces Poultry (Chicken Breast, etc.)	165° F

\* United States Department of Agriculture

**SAFE STORAGE AND MAINTENANCE**

- Inspect all hardware in assembled parts for tightness on a regular basis to insure unit is in safe working condition.
- ALWAYS allow unit to cool completely before handling.
- Clean unit, including special surfaces such as cooking grates with mild cleaning agents. Wipe outside of unit with damp rag. DO NOT use oven cleaner.
- ALWAYS cover and store cold unit in a protected area.
- Unit is made of steel and may rust over time. If rusting occurs on outside surfaces, clean area with sand paper or steel wool, then cover with heat resistant paint.
- NEVER USE PAINT ON INSIDE SURFACES OF UNIT.
- ALWAYS empty drip tray, located in back of post, after each use.
- When grill is not in use, grill must be turned OFF.
- With normal use, some bronzing may occur. This applies to stainless steel unit only.
- Do not burn trash, leaves, paper, cardboard or wood in grill.

**PLACEMENT OF APPLIANCE FOR SAFETY**

**WARNING**  
Minimum distance from side and back of appliance to walls or railing is 2ft (61cm).

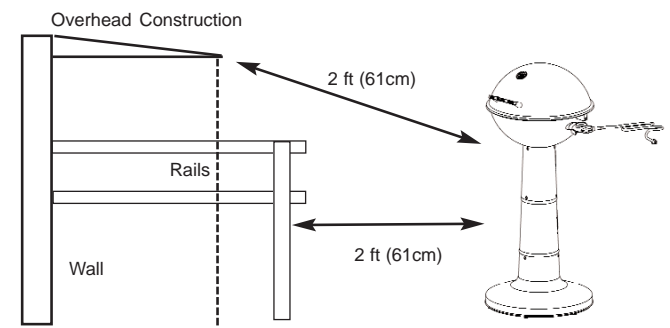

# TROUBLESHOOTING GUIDE

SYMPTOM	CAUSE	POSSIBLE SOLUTION
Power light won't come on.	Not plugged into outlet	Check outlet connection
	Control unit cord not plugged into base pan	Check unit connection
	House fuse tripped	Make sure other appliances are not operating on the same electrical circuit. Check household fuses
	Controller malfunctioning	Contact Masterbuilt at 1.800.489.1581
Unit takes excessive amount of time to heat up, (longer than 15-20 min) or not enough heat	Unit plugged into an extension cord lid	Set unit so an extension cord does not have to be used
	Lid not in place	Close lid to retain heat in unit
	Controller malfunctioning	Contact Masterbuilt at 1-800-489-1581
Controller does not adjust heat	Not plugged into wall	Check wall connection
	Control unit cord not plugged into base pan	Check unit connection
	Controller malfunctioning	Contact Masterbuilt at 1-800-489-1581
Grill reaches extremely high temperatures	Temperature setting too high	Adjust controller to lower setting
	Controller/element malfunctioning	Contact Masterbuilt at 1-800-489-1581
Frequent flare-ups	Cooking fatty foods	Use low temperature setting with lid open
	Grease build-up	Clean internal base pan
Power light is on, unit isn't heating	Controller malfunctioning	Contact Masterbuilt at 1.800.489.1581
	Faulty element	Contact Masterbuilt at 1.800.489.1581

## PARTS LIST

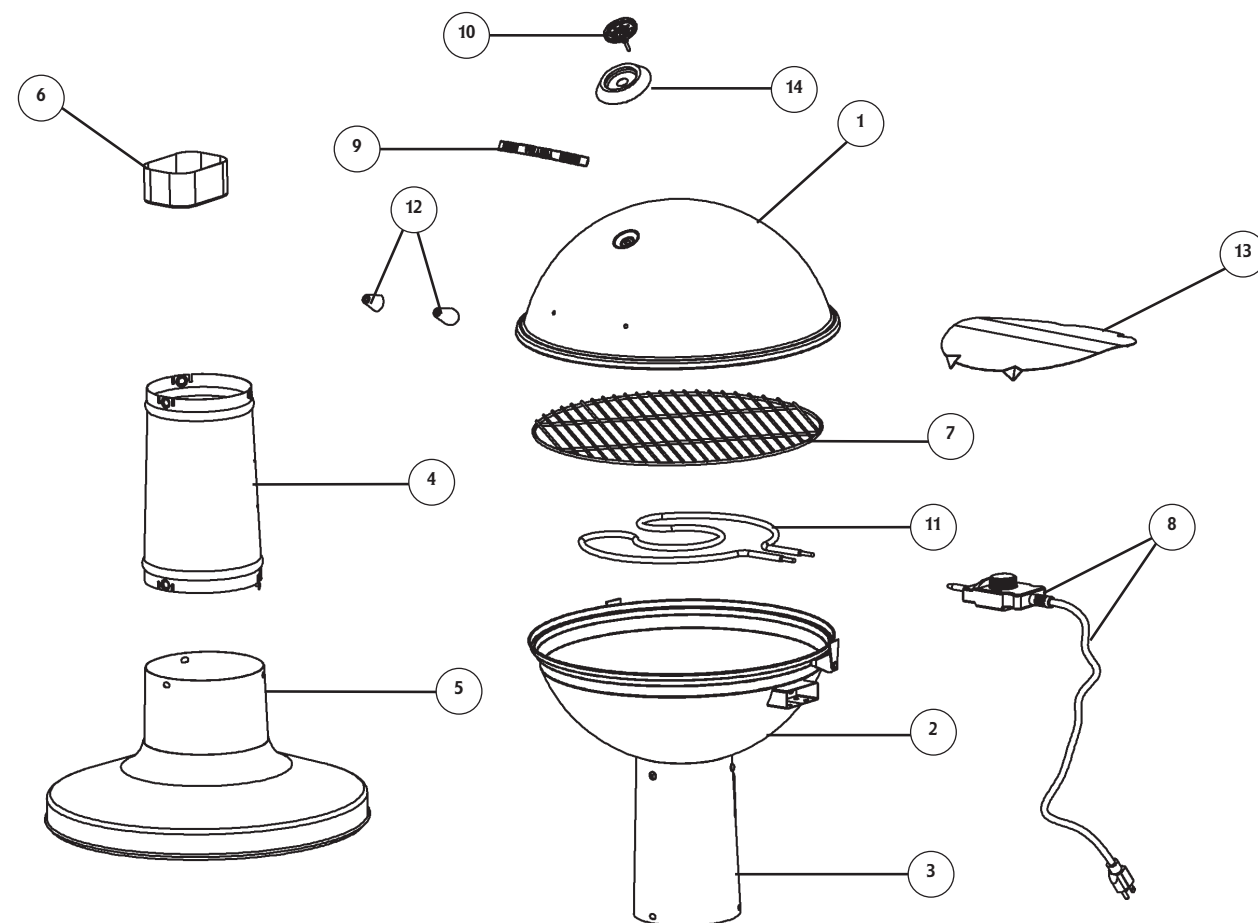

ITEM NO.	QUANTITY	DESCRIPTION	ITEM NO.	QUANTITY	DESCRIPTION
1	1	Grill Lid	8	1	Control Unit w/ Cord
2	1	Grill Base	9	1	Handle
3	1	Pedestal Top	10	1	Temperature Gauge
4	1	Pedestal Middle	11	1	Element
5	1	Pedestal Bottom	12	2	Spacer
6	1	Grease Cup	13	1	Reflector Plate
7	1	Cooking Grate	14	1	Beauty Ring

## HARDWARE LIST



**(A)**  
M6x10  
Hitch Pin  
qty - 2

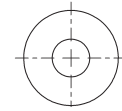

**(B)**  
M6  
Flat Washer  
qty - 2

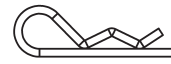

**(C)**  
Hair Pin  
qty - 2

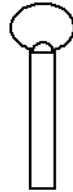

**(D)**  
M5x10  
Thumb Screw  
qty - 2



**(E)**  
M6x10  
Phillips Flange Screw  
qty - 9

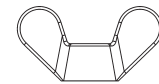

**(F)**  
M8  
Wing Nut  
qty - 1  
(packed with temperature gauge)

## REPLACEMENT PARTS LIST

ITEM NO.	DESCRIPTION
990000130	Base Kit
990000131	Pedestal Middle Kit
990000132	Outer Bowl Kit
99150002	Lid Kit
990070085	Lid Handle Kit
99150001	Element Kit
99150003	Temperature Gauge Kit
15080003	Reflector Plate
900000423	Cooking Grate
900000424	Grease Cup
15080007	Control Unit w/ Cord
15080024	Grill Cover (Polyester)
15080022	Instruction Manual
15080008	Hardware Bag



**DO NOT RETURN TO RETAILER**  
For Assembly Assistance, Missing or Damaged Parts  
Call: MASTERBUILT Customer Service at 1-800-489-1581

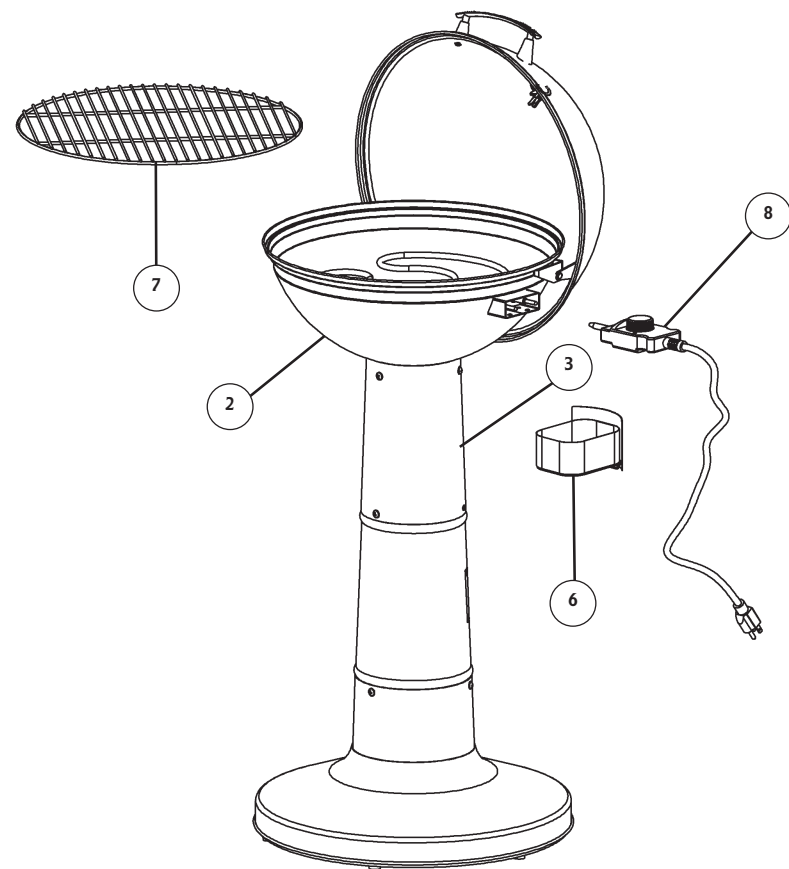

**STEP 7.**  
Place cooking grate (7) inside grill base (2).  
Insert grease cup (6) into back of pedestal top (3).  
Connect control unit (8) to grill base (2).

**GRILL IS READY FOR USE.**

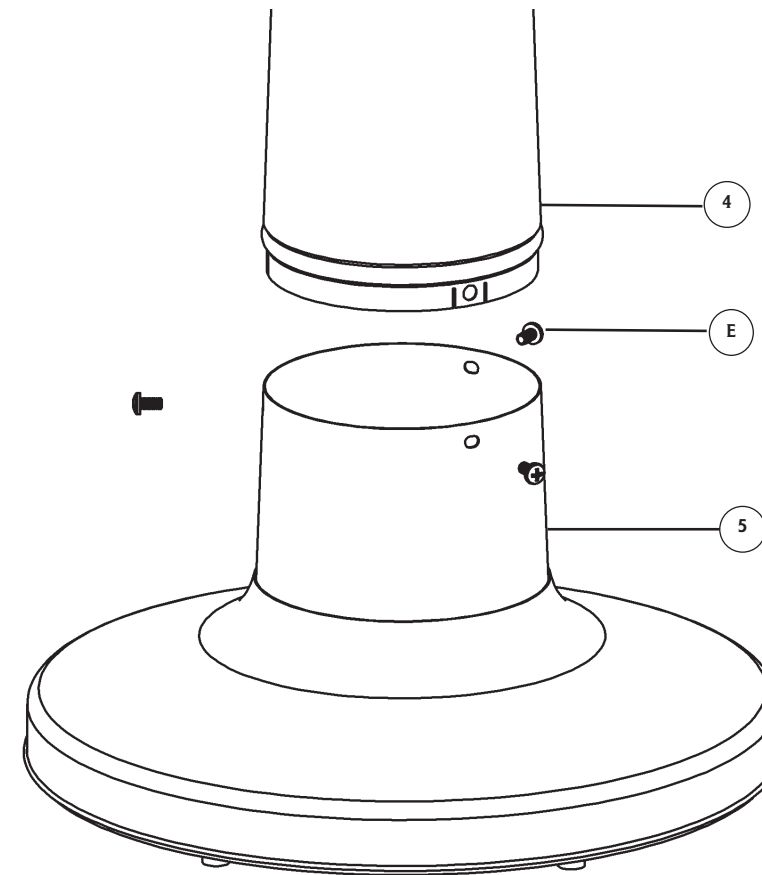

**Before assembly read instructions carefully.**

**Tools needed for assembly:**  
Phillips Head Screwdriver

**Assemble unit on a clean, flat surface.**

**Carefully position grill as shown.**

**STEP 1.**  
Attach pedestal middle (4) to pedestal base (5) using phillips flange screws (E).

**CONTROL UNIT  
APPROXIMATE TEMPERATURE SETTINGS**



CONTROL UNIT SETTING	APPROXIMATE TEMPERATURE
LO	352°F (178°C)
MED	460°F (238°C)
HI	575°F (302°C)

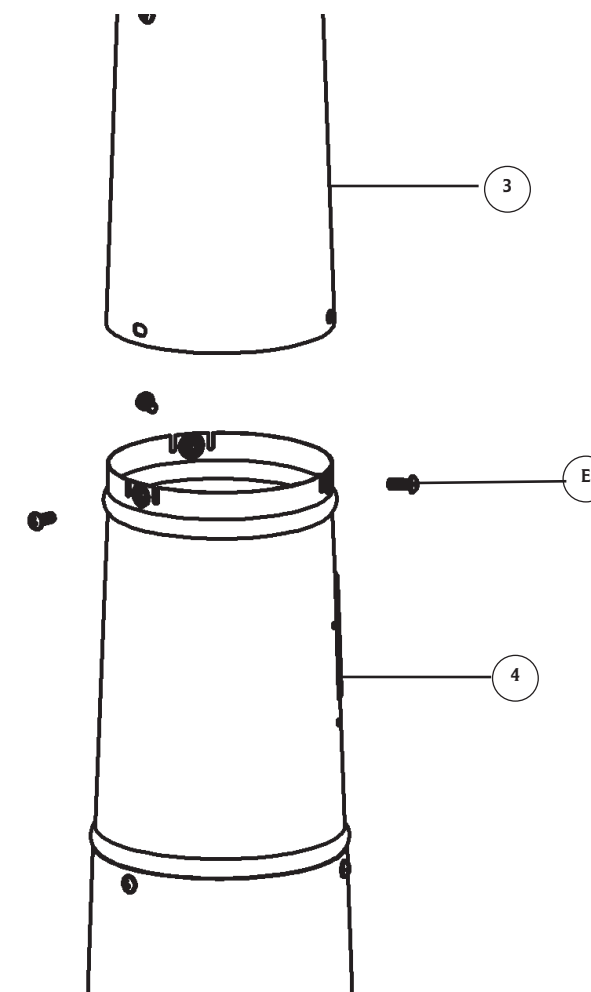

**STEP 2.**  
Attach pedestal top (3) to assembled pedestal middle (4) as shown using phillips flange screws (E).

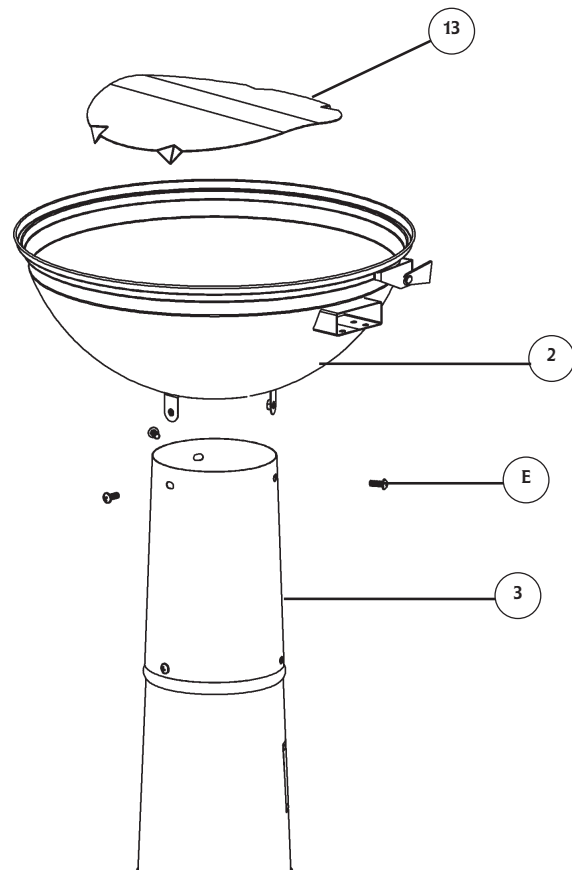

**STEP 3.**  
Attach grill base (2) to assembled pedestal top (3) as shown using phillips flange screws (E).

Insert reflector plate (13) into grill base as shown.

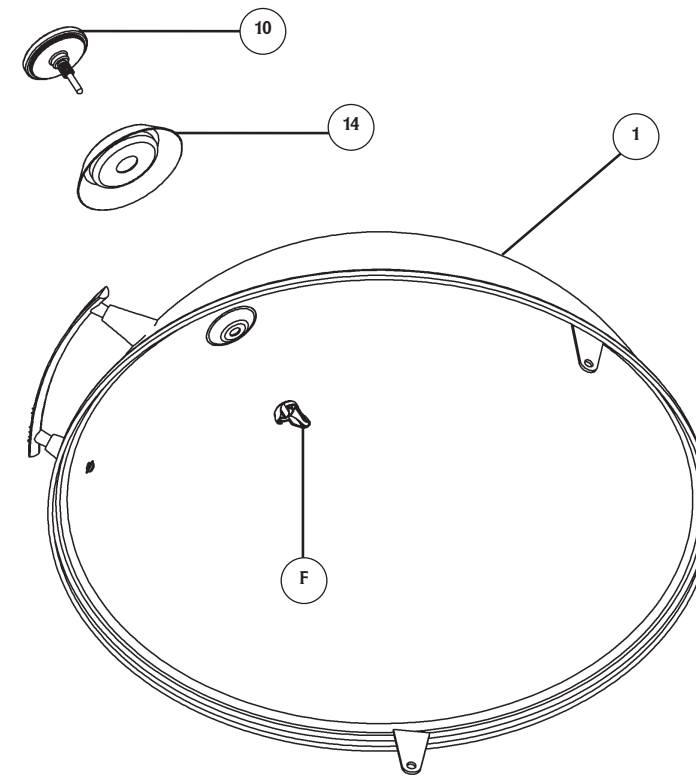

**STEP 5.**  
Insert stem of temperature gauge (10) through beauty ring (14) into grill lid (1). Secure using wing nut (F) as shown.

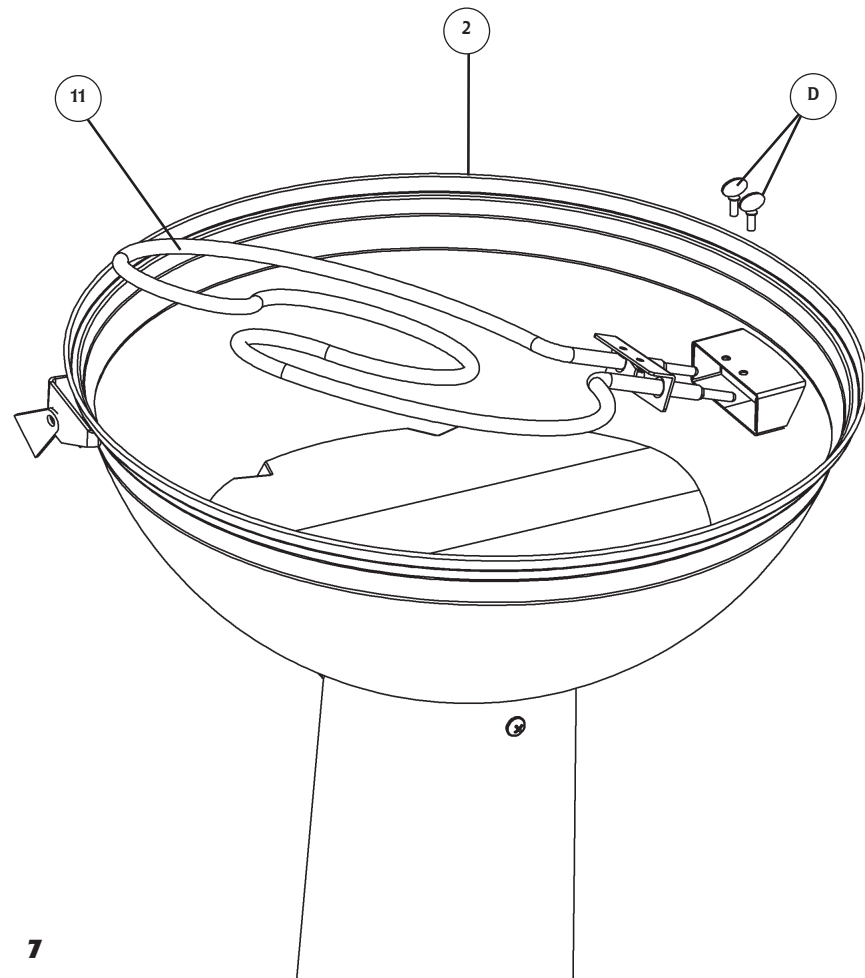

**STEP 4.**  
Insert element (11) into grill base (2) as shown. Align holes in element and grill base. Secure using thumb screws (D).

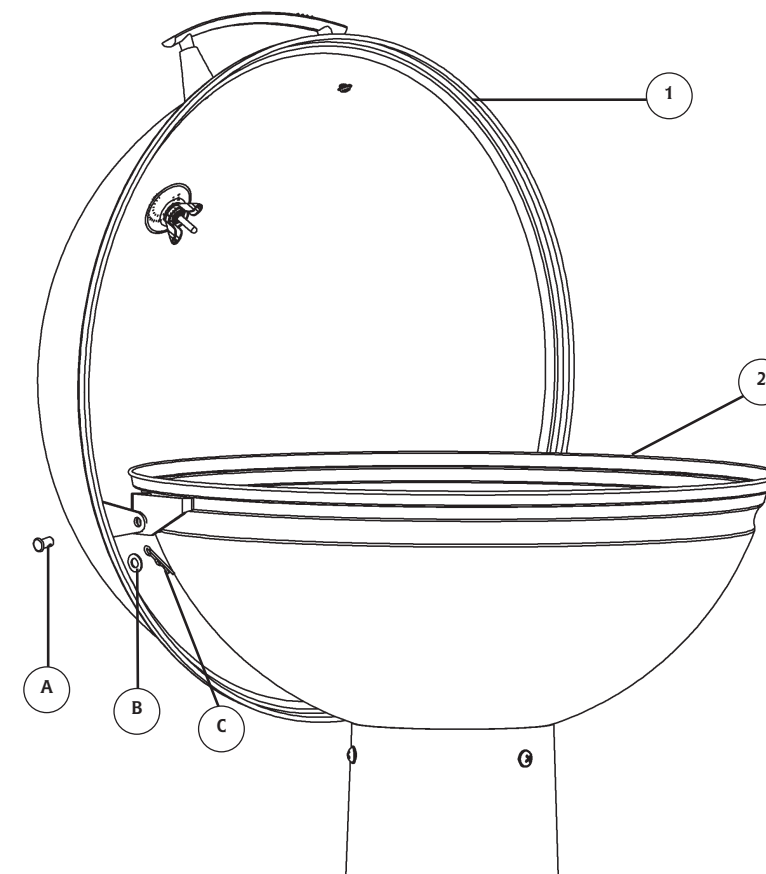

**STEP 6.**  
Align hinge on grill lid (1) with hinge on grill base (2). Insert hitch pin (A) through aligned holes as shown. Attach flat washer (B) to end of hitch pin. Secure using hair pin (C).

Repeat Step 3 on opposite side.

